

Appendix I

Trash Capture Devices Offered Through the Project

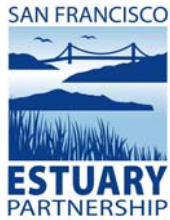

Trash Capture Devices approved by San Francisco Bay Regional Water Quality Control Board staff

Devices listed with Device ID numbers are included in the Estuary Partnership's Bay Area-wide Trash Capture Demonstration Project. Other devices have also been approved by Water Board staff. SFEP will update this list as needed.

CATCH BASIN INSERTS		
SFEP Device ID	Vendor	Device Name
AS-1	Advanced Solutions	Stormtek ST3
AS-2	Advanced Solutions	Stormtek ST3-G
	Best Management Products, Inc.	SNOUT Oil-Debris Separator (with Trash Screen)
BC-1	Bio Clean Environmental Services, Inc.	Grate Inlet Skimmer Box (square design)
BC-2	Bio Clean Environmental Services, Inc.	High Capacity Round Grate Inlet Skimmer Box
BC-3	Bio Clean Environmental Services, Inc.	Modular Connector Pipe Screen
BC-4	Bio Clean Environmental Services, Inc.	Trash Guard
	Coanda Inc.	Coanda Screen and Debris Fence
ECI-1	Ecology Control Industries	Debris Dam
G2-1	G2 Construction, Inc.	Collector Pipe Screen
G2-1R	G2 Construction, Inc.	Collector Pipe Screen Removable
GFI-1	Gentile Family Industries	Wavy Grate Trash Catcher
KS-1	KriStar Enterprises, Inc.	Flo Gard Plus Catch Basin Filter Insert, combination inlet style – C3 (stainless steel)
KS-2	KriStar Enterprises, Inc.	Flo Gard Plus Catch Basin Filter Inserts, flat grated inlet style, rectangular or round – C3 (stainless steel)
KS-3	KriStar Enterprises, Inc.	FloGard Catch Basin Outlet Screen Insert
REM-1	Revel Environmental Manufacturing, Inc.	Triton Bioflex Drop Inlet Trash Guard
USW-1	United Stormwater, Inc.	Connector Pipe Screen
USW-5	United Stormwater, Inc.	DrainPac – Drop Inlet
WCS-1	West Coast Storm, Inc.	Connector Pipe Screen
	Xeripave, LLC	Storm Grate Baskets with screened 10" sidewall

CURB INLET SCREENS – FOR USE IN COMBINATION WITH INSERTS

SFEP Device ID	Vendor	Device Name
ECI-2	Ecology Control Industries	Surfgate
G2-2	G2 Construction, Inc.	CamLock Debris Gate
G2-3	G2 Construction, Inc.	FS 10
GFI-2	Gentile Family Industries	ARS – automatic retractable screen
KS-4	KriStar Enterprises, Inc.	Trash and Debris Guard
USW-2	United Stormwater, Inc.	Clean Screen III -ARS
USW-3	United Stormwater, Inc.	Manual Retractable Screen -MRS
USW-4	United Stormwater, Inc.	DrainPac – Curb Inlet
WCS-2	West Coast Storm, Inc.	ARS – automatic retractable screen

HIGH FLOW CAPACITY DEVICES

SFEP Device ID	Vendor	Device Name
BC-5HF	Bio Clean Environmental Services, Inc.	Nutrient Separating Baffle Box
CCP-1HF	Contech Construction Products	Continuous Deflective Separator (CDS)
FCT-1HF	Fresh Creek Technologies, Inc.	Inline Netting Trash Trap
FCT-2HF	Fresh Creek Technologies, Inc.	End of Pipe Netting Trash Trap
KS-5HF	KriStar Enterprises, Inc.	CleansAll
KS-6HF	KriStar Enterprises, Inc.	Downstream Defender
KS-7HF	KriStar Enterprises, Inc.	FloGard Dual-Vortex Hydrodynamic Separator
KS-8HF	KriStar Enterprises, Inc.	FloGard Perk Filter
KS-9HF	KriStar Enterprises, Inc.	FloGard Swirl-Flo Screen Separator
KS-10HF	KriStar Enterprises, Inc.	Nettech Gross Pollutant Trap - In Line
KS-11HF	KriStar Enterprises, Inc.	Nettech Gross Pollutant Trap- End of Line
RMC-1HF	Roscoe Moss Company	Storm Flo Screen

Catchbasin Insert, Full Capture Device

WCS-1 Connector Pipe Screen Connector pipe screen

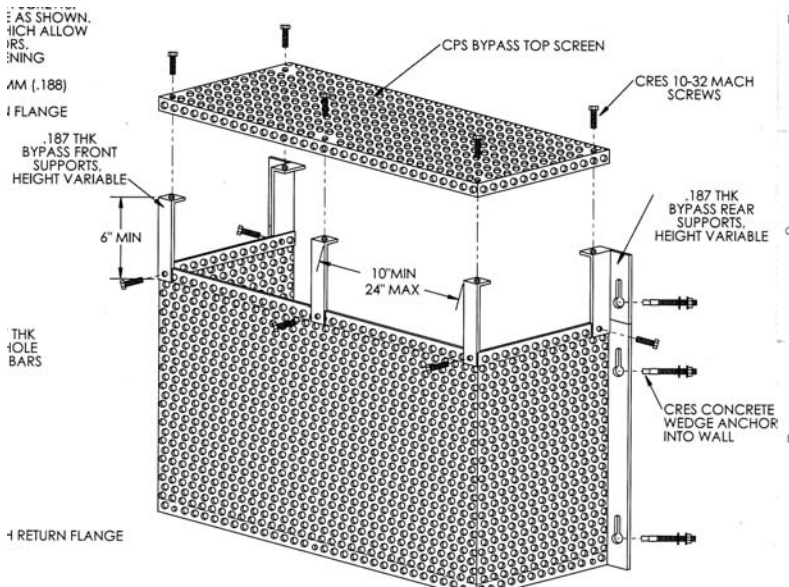

<p>Company Contact: West Coast Storm, Inc., San Bernardino, CA Sales contact: Brian Martello, (909)717-8855 bmartello@wcstorm.net http://westcoaststorm.com</p>	<p>Meets San Francisco Bay Water Board full capture specifications</p>
<p>Storage capacity: Depends on size of catchbasin</p>	<p>Replacement Parts: Available</p>
<p>Vendor's maintenance estimate: Maintenance crews should inspect and clean catch basins and installed devices bi-annually and/or immediately following a significant storm event.</p>	<p>Warranty: 10 yrs on parts</p>
<p>Material: Stainless steel</p>	<p>Delivery Time: "Estimated 3 days time per 1 day quantity of installs"</p>
<p>Pricing: See over. Have uninstalled price</p>	

Comments from reference checks

Device effectiveness in capturing trash

"In certain areas, very large storms may flood the CPS device. I do not recommend the placement of CPS devices on slopes or areas with a grade. Our experience is that trash will flow right past the devices."

"Only install in areas that are not prone to flooding. If an area is prone to flooding, the device will flood."

Bay Area-wide Trash Capture Demonstration Project

Funded by the Clean Water State Revolving Fund and the American Recovery and Reinvestment Act



Pricing, including installation, is as follows:

Per unit cost for CPS Devices fitting a connector pipe of 6 inches to 48 inches.

For orders of 25 CPS devices or more:

\$ 428.18 each CPS device

Per unit cost for CPS Devices fitting a connector pipe of 6 inches to 48 inches.

For orders of 24 CPS devices or less:

\$ 575.00 each CPS device

West Coast Storm

WCS-1

Connector Pipe Screen

Including Installation

Device ID	Outlet Pipe Dimensions	Quantity	Price Stainless Baskets (C3) Per Unit
WCS-1	6" – 48"	1-24	\$ 575.00
WCS-1	6" – 48"	24 or more	\$ 428.18

Not Including Installation

Device ID	Outlet Pipe Dimensions	Quantity	Price Stainless Baskets (C3) Per Unit
WCS-1	6" – 48"	1 or more	\$370.00

Pricing, **NOT including installation**, is as follows:

Warranty is void if the device is not installed by a WCS Certified Installer. For single orders of 200 or more CPS devices, WCS will train and certify qualified installers. Price includes parts for installation of unit. Price does not include ACCESS database or drain mapping provisions as stated in vendor contract.

WCS-2

ARS- Automatic Retractable Screen

Including Installation

Device ID	Length	Quantity	Price Per Unit
WCS-2	Up to 48"	1 or more	\$327.00

Not Including Installation

Device ID	Length	Quantity	Price Per Unit
WCS-2	Up to 48"	1 or more	\$270.00

Pricing, **NOT including installation**, is as follows:

Warranty is void if the device is not installed by a WCS Certified Installer. For single orders of 200 or more ARS devices, WCS will train and certify qualified installers. Price includes parts for installation of unit. Price does not include ACCESS database or drain mapping provisions as stated in vendor contract

Catchbasin Insert, Full Capture Device

USW-1 Connector Pipe Screen

Connector pipe screen

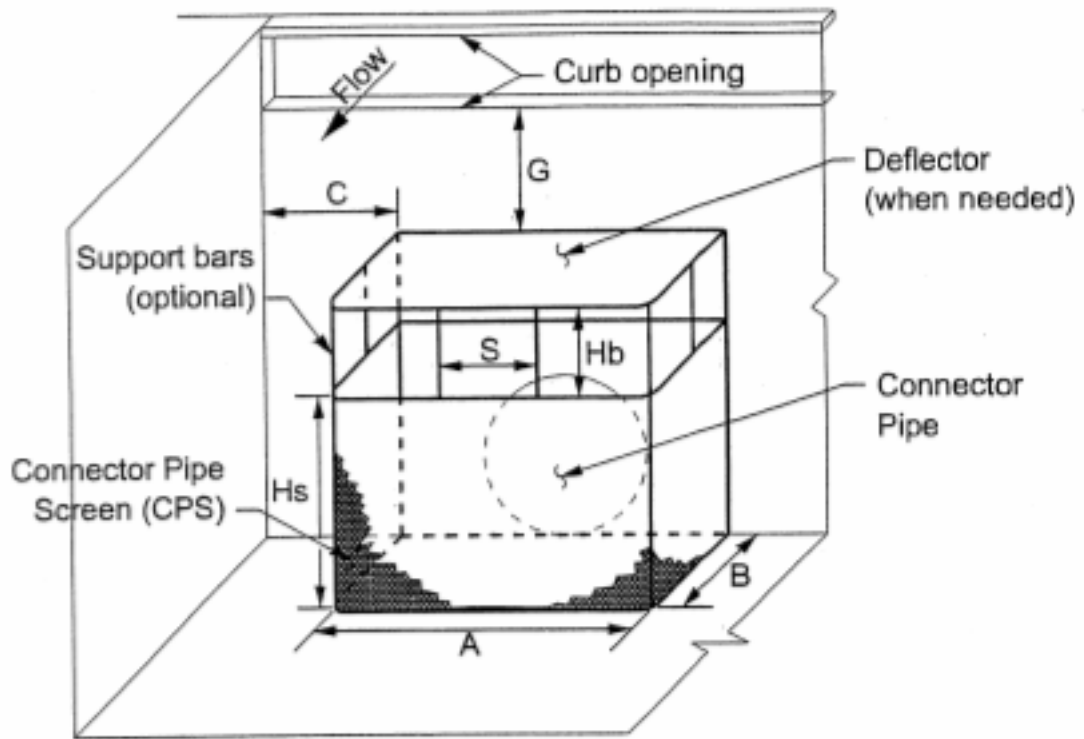

<p>Company Contact: United Stormwater, Inc., City of Industry, CA Sales contact: Chris Anguiano, 626-290-5372 christian@unitedpumping.com http://www.unitedstormwater.com</p>	<p>Meets San Francisco Bay Water Board full capture specifications</p>
<p>Storage capacity: Depends on size of catchbasin</p>	<p>Replacement Parts: Available</p>
<p>Vendor's maintenance estimate: "The catchbasin and CPS will need to be cleaned with a vacuum truck to remove the debris captured. Cleaning will take about 15-25 minutes per basin"</p>	<p>Warranty: 3 yrs</p>
<p>Material: 304 stainless steel</p>	<p>Delivery Time: Depending on the size of order, availability of material is generally 4-6 weeks, plus 2 weeks for manufacturing/installation.</p>
<p>Pricing: See over.</p>	

Comments from reference checks

Device effectiveness in capturing trash

"The CPS device does an adequate job. There is better workmanship out there....The devices mostly capture vegetation and sand." (Used in commercial areas)

Bay Area-wide Trash Capture Demonstration Project

Funded by the Clean Water State Revolving Fund and the American Recovery and Reinvestment Act

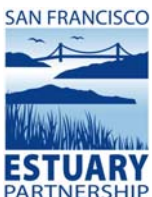

United Stormwater Full-Capture Devices

USW-1 Connector Pipe Screen

***Minimum order is 5 units**

Device ID	Quantity	Price
USW-1	5 to 9	\$515.00
USW-1	10 to 49	\$475.00
USW-1	50 to 99	\$425.00
USW-1	100 or more	\$409.00

Prices exclude cleaning of Catch Basin, disposal of material. Price subject to increases in cost and material

United Stormwater Partial Capture Devices

USW-2 Clean Screen III

***Minimum order is 5 units**

Device ID	Quantity	Price
USW-2	5 to 9	\$636.00
USW-2	10 to 49	\$560.00
USW-2	50 to 99	\$515.00
USW-2	100 or more	\$490.00

Prices exclude cleaning of Catch Basin, disposal of material. Price subject to increases in cost and materials

USW-3 Manual Retractable Screen (Curb Inlet Screen)

Device ID	Quantity	Price
USW-3	1 to 9	\$450.00
USW-3	10 to 49	\$425.00
USW-3	50 to 99	\$400.00
USW-3	100 or more	\$375.00

USW-4 - DrainPac (Curb Inlet Design)

***Prices do not include installation**

Device ID	Size	Price
USW-4a	41"x12"x12"	\$375.00
USW-4b	48"x12"x12"	\$425.00
USW-4c	60"x12"x12"	\$475.00
USW-4d	82"x12"x12"	\$525.00

USW-5 - DrainPac (Drop Inlet Design)

***Prices do not include installation**

Device ID	Size	Price
USW-5a	12"x12"	\$275.00
USW-5b	18"x18"	\$325.00
USW-5c	24"x24"	\$385.00
USW-5d	36"x36"	\$450.00
USW-5e	48"x48"	\$650.00
USW-5f	25"x38"	\$425.00

Catchbasin Insert, Full Capture Device

REM-1 Triton Bioflex Drop Inlet Trash Guard Catchbasin filter insert

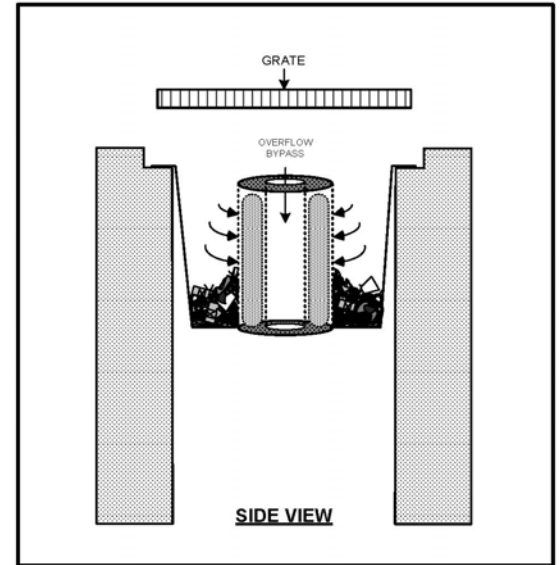
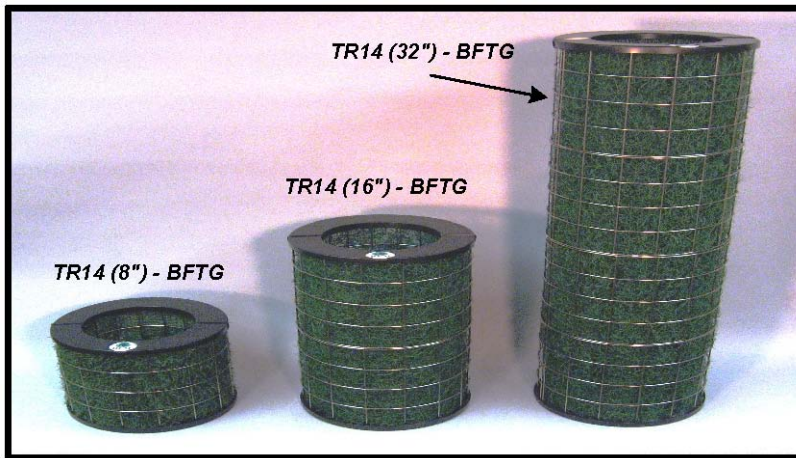

<p>Company Contact: Revel Environmental Manufacturing, Inc., Concord, CA Sales contact: Marcel Sloane, (925)-676-4736 Marcel@remfilters.com http://remfilters.com</p>	<p>Meets San Francisco Bay Water Board full capture specifications</p>
<p>Storage capacity: Depends on each catchbasin's configuration, size of filter, etc.</p>	<p>Replacement Parts: Available, Replacement Filters</p>
<p>Vendor's maintenance estimate: The filter cleaning process and Bioflex media replacement should take no more than 15 minutes per filter. Maintained when debris accumulates up to 80% of the filter's capacity. Minimum 3 times per year.</p>	<p>Warranty: 1 yr, or 6 if REM contracts to do maintenance</p>
<p>Material: High density polyethylene, 304 stainless steel, polyester fiber mesh, coir fibers, water-based latex</p>	<p>Delivery Time: Within three weeks from receipt of order</p>
<p>Pricing: See over.</p>	
<p>Installed: Dublin</p>	

Comments from reference checks

Device effectiveness in capturing trash

Good, effective device in capturing trash (no complaints from the public or flooding occurring in the street).

Maintenance

Maintenance included 3 times a year but at a reasonable price by a contractor. Disposal of filters is an additional maintenance consideration (and an extra service also provided by cleaning contractor)

Other

Good customer service from vendor. Easy installation under the vendor's scheduled time quote. Some modifications were needed for installation based on field conditions. Optional hydrocarbon (oil, grease) removal is also available.

Bay Area-wide Trash Capture Demonstration Project

Funded by the Clean Water State Revolving Fund and the American Recovery and Reinvestment Act





Revel Environmental Manufacturing Inc.

sales@remfilters.com (888) 526-4736 Lic. No. 857410

Northern California
 960-B Detroit Avenue
 Concord, California 94518
 P: (925) 676-4736
 F: (925) 676-8676

Southern California
 2110 South Grand Avenue
 Santa Ana, California 92705
 P: (714) 557-2676
 F: (714) 557-2679

REM TRITON Bioflex Trash Guard (BFTG) Price List

Pricing includes municipal consultation, catch basin sizing, delivery and installation of complete TRITON BFTG filter system.

TR - BFTG Series (For Drop Inlets)		TRC - BFTG Series (For Curb Inlets)	
Catch Basin Size	Quantity Pricing	Curb Inlet Size	Quantity Pricing
1' x 1' thru 1.5' x 2'	1 to 50: \$255ea.	2' thru 4'	1 to 50: \$360ea.
	51 to 99: \$240ea.		51 to 99: \$340ea.
	100 or more: \$230ea.		100 or more: \$320ea.
2' x 2' thru 2.5' x 2.5'	1 to 50: \$335ea.	5' thru 7'	1 to 50: \$525ea.
	51 to 99: \$320ea.		51 to 99: \$499ea.
	100 or more: \$300ea.		100 or more: \$470ea.
2' x 3' thru 4' x 4'	1 to 50: \$595ea.	TRITON Curb Inlet filters are be teamed together inline and scalable for varying curb opening lengths. Most S. F. Bay Area curb style inlet openings range from 2 to 7' in length. Please call REM for more information regarding curb inlets openings longer than 7 feet.	
	51 to 99: \$565ea.		
	100 or more: \$535ea.		
Replacement Bioflex Media Pricing for TR - BFTG			
Drop Inlet Cartridge Model	Price		
TR6.5 (8") - BFTG	\$14.75ea.		
TR10 (8") - BFTG	\$14.75ea.		
TR14 (8") - BFTG	\$14.75ea.		
TR10 (16") - BFTG	\$16.25ea.		
TR14 (16") - BFTG	\$16.25ea.		
TR24 (17") - BFTG	\$19.50ea.		
TR24 (17") - BFTG	\$19.50ea.		
Drop inlet pricing is based on standard 8" and 16" cartridge height configurations. Taller cartridge configurations are available upon request			
Replacement Bioflex Media for TRC - BFTG			
Bioflex Replacement Media Pricing is: \$3.70 per ft. / Linear Foot.			

Notes:

REM O&M Service programs include Bioflex media replacement. Custom service programs are available including; "Cartridge Core Change-out and Swap" upon request.

REM recommends that Bioflex Media be replaced at least once per year.

Pricing for Replacement Bioflex Media does not include delivery or installation.

REM-1
REM Triton Bioflex Trash Guard

TR - BFTG Series (For Drop Inlets)

Device ID	Catch Basin Size	Quantity	Pricing per Unit
REM-1a	1' x 1' thru 1.5' x 2'	1 to 50	\$255.00
REM-1a	1' x 1' thru 1.5' x 2'	51 to 99	\$240.00
REM-1a	1' x 1' thru 1.5' x 2'	100 or more	\$230.00
REM-1b	2' x 2' thru 2.5' x 2.5'	1 to 50	\$335.00
REM-1b	2' x 2' thru 2.5' x 2.5'	51 to 99	\$320.00
REM-1b	2' x 2' thru 2.5' x 2.5'	100 or more	\$300.00
REM-1c	2' x 3' thru 4' x 4'	1 to 50	\$595.00
REM-1c	2' x 3' thru 4' x 4'	51 to 99	\$565.00
REM-1c	2' x 3' thru 4' x 4'	100 or more	\$535.00

TR- Replacement Bioflex Media Pricing for TR – BFTG

Device ID	Outflow Pipe Diameter	Cartridge Height	Pricing per Unit
REM-1d	6.5"	8"	\$14.75
REM-1e	10"	8"	\$14.75
REM-1f	14"	8"	\$14.75
REM-1g	10"	16"	\$16.25
REM-1h	14"	16"	\$16.25
REM-1i	24"	17"	\$19.50
REM-1j	24"	17"	\$19.50

Note: Drop inlet pricing is based on standard 8" and 16" cartridge height configurations. Taller cartridge configurations are available upon request. Pricing includes municipal consultation, catch basin sizing, delivery and installation of complete TRITON BFTG filter system

TRC - BFTG Series (For Curb Inlets)

Device ID	Curb Inlet Size	Quantity	Pricing per Unit
REM-1k	2' to 4'	1 to 50	\$360.00
REM-1k	2' to 4'	51 to 99	\$340.00
REM-1k	2' to 4'	100 or more	\$320.00
REM-1l	5' to 7'	1 to 50	\$525.00
REM-1l	5' to 7'	51 to 99	\$499.00
REM-1l	5' to 7'	100 or more	\$470.00

Replacement Bioflex Media for TRC – BFTG

Device ID	Pricing per Linear Foot
REM-1m	\$3.70

Notes: REM O&M Service programs include Bioflex media replacement. Custom service programs are available including; "Cartridge Core Change-out and Swap" upon request. REM recommends that Bioflex Media be replaced at least once per year. Pricing for Replacement Bioflex Media does not include delivery or installation.

Catchbasin Insert, Full Capture Device

KS-3 FloGard catchbasin Outlet Screen Inserts "Outlet Trash Screens" = Connector Pipe Screens

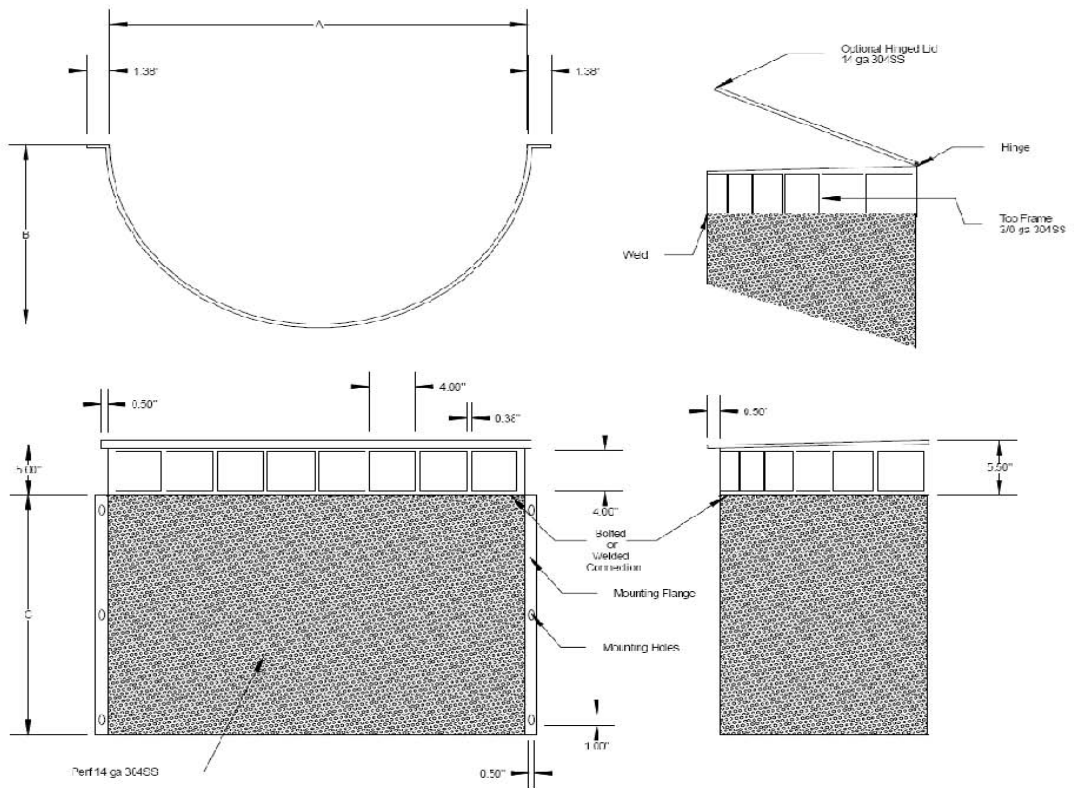

<p>Company Contact: KriStar Enterprises, Inc., Santa Rosa, CA Sales contact: Sue Lillo, 800-579-8819 slillo@kristar.com http://www.kristar.com</p>	<p>Meets San Francisco Bay Water Board full capture specifications</p>
<p>Storage capacity: 7-10 cubic feet depending on size of catch basin</p>	<p>Replacement Parts: Available</p>
<p>Vendor's maintenance estimate: "Depends on the amount of runoff, pollutant loading and interference from debris"</p>	<p>Warranty: 5 years</p>
<p>Material: 304 stainless steel</p>	<p>Delivery Time: From receipt of order, typically 2-3 weeks</p>
<p>Pricing: See over.</p>	
<p>Installed: FloGard inserts are in use in County of Sonoma, Alameda County Transit, Santa Clara Valley Transit Authority, Riverside County-TLMA</p>	

No reference information was available for this device

Bay Area-wide Trash Capture Demonstration Project
Appendix B- Item Q Pricing Schedule

Name of Proposing Company: KriStar Enterprises, Inc.
Name of Device: FloGard Catch Basin Outlet Screens

	PIPE OUTLET MAXIMUM DIAMETER	UNIT PRICE
Small	18"	\$ 795.00
Medium	24"	\$ 905.00
Large	36"	\$ 995.00

- (1) Actual dimensions will be field verified by KriStar prior to fabrication and installation
- (2) Products manufactured in accordance with Buy American contract provisions
- (3) Prices include manufacturer installation
- (4) Prices do not include any applicable sales taxes
- (5) There are no quantity purchase discounts available for this item

Small Devices

KS-1

Combination Inlet Catch Basins

Device ID	Inside Dimensions	Price Stainless Baskets (C3) Per Unit
KS-1a	12 " x 12" - 24" x 24"	\$ 460.00
KS-1b	18"x 36" - 36" x 36"	\$ 530.00

KS-2(rect)

Flat Grated inlet style, Rectangular Inlet C3

Device ID	Inside Dimensions	Price Stainless Baskets (C3) Per Unit
KS-2a	12 " x 12" - 21" x 21"	\$405.00
KS-2b	22" x 22" - 24" x 36"	\$520.00
KS-2c	30" x 36" - 48" x 48"	\$880.00

KS-2(round)

Flat Grated inlet Style, Round Circular Inlet C3

Device ID	Inside Dimensions	Price Stainless Baskets (C3) Per Unit
KS-2d	12" - 21"	\$ 410.00
KS-2e	22" - 36"	\$ 620.00

NOTES:

- (1) Actual dimensions will be field verified by KriStar prior to fabrication/installation
- (2) Products manufactured in accordance with Buy American contract provisions
- (3) Prices include manufacturer installation
- (4) Prices do not include any applicable sales taxes
- (5) The following discounts are available for volume purchases
10-25 units Deduct \$10.00 per catch basin from above prices
More than 25 units Deduct \$25.00 per catch basin from above prices
- (6) Optional Items
 - (a) Fossil Rock Pouches @ \$15.00 per pouch
 - (b) Stainless Steel Trash and Debris Guards @ \$375.00 per each

KS-3

FlowGard Catch Basin Outlet Screen Insert

Device ID	Pipe Outlet Maximum Diameter	Unit Price
KS-3a	18"	\$ 795.00
KS-3b	24"	\$ 905.00
KS-3c	36"	\$995.00

- (1) Actual dimensions will be field verified by KriStar prior to fabrication and installation
- (2) Products manufactured in accordance with Buy American contract provisions
- (3) Prices include manufacturer installation

- (4) Prices do not include any applicable sales taxes
- (5) There are no quantity purchase discounts available for this item

KS-4

Trash and Debris Guards (stainless steel)

Device ID	Unit Price
KS-4	\$ 375.00

Large Devices

KS-5HF

Cleans All Gross Pollutant Trap

Device ID	Unit Price
KS-5HF	Pricing for this product is estimated to range from \$60,000 to \$220,000 per installation. Each location will need to be individually evaluated to determine final pricing based upon the site specific conditions.

KS-6HF

Downstream Defender

Device ID	Unit Price
KS-6HF4	\$ 12,900.00
KS-6HF6	\$ 22,500.00
KS-6HF8	\$37,500.00
KS-6HF10	\$65,000.00

NOTES:

- (1) Actual dimensions will be field verified by KriStar prior to fabrication and installation
- (2) Products manufactured in accordance with Buy American contract provisions
- (3) Prices include precast concrete components, bolted, gasketed lids, factory-installed internal components and delivery to jobsite
- (4) Purchaser is responsible for offloading and setting of structures
- (5) Prices do not include diversion structures
- (6) Prices do not include any applicable sales taxes
- (7) There is no purchase quantity discount available for this product

Catchbasin Insert, Full Capture Device

KS-2 Flo Gard Plus catchbasin Filter Inserts, flat grated inlet style, rectangular or round, stainless steel only (C3)
Drop in Basket

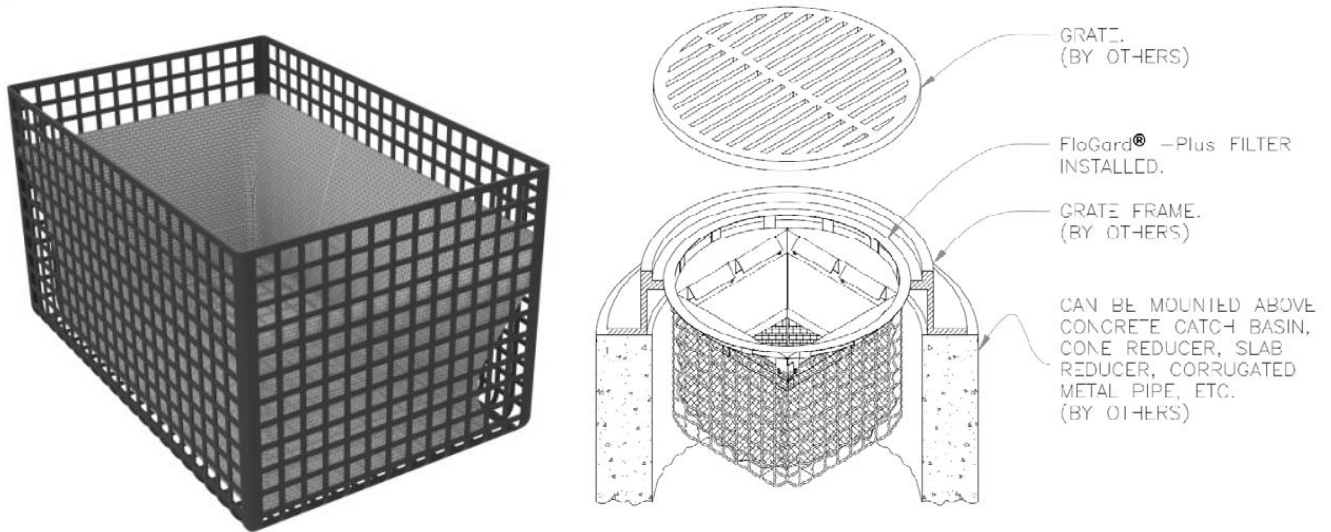

<p>Company Contact: KriStar Enterprises, Inc., Santa Rosa, CA Sales contact: Sue Lillo, 800-579-8819 slillo@kristar.com http://www.kristar.com</p>	<p>Meets San Francisco Bay Water Board full capture specifications</p>
<p>Storage capacity: Rectangular (0.4-10.5 cubic feet) Round (0.7-4.3 cubic feet)</p>	<p>Replacement Parts: Available</p>
<p>Vendor's maintenance estimate: "Depends on the amount of runoff, pollutant loading and interference from debris"</p>	<p>Warranty: 5 years</p>
<p>Material: 304 stainless steel</p>	<p>Delivery Time: Typically 1 week for standard products; 3 weeks for customized products</p>
<p>Pricing: See over.</p>	
<p>Installed: FloGard inserts are in use in County of Sonoma, Alameda County Transit, Santa Clara Valley Transit Authority, Riverside County-TLMA</p>	

Only the stainless steel version of this device is accepted in the project.

No reference information was available for this device

Bay Area-wide Trash Capture Demonstration Project

Funded by the Clean Water State Revolving Fund and the American Recovery and Reinvestment Act



Bay Area-wide Trash Capture Demonstration Project
Appendix B- Item Q Pricing Schedule

Name of Proposing Company: **KriStar Enterprises, Inc.**
Name of Device: **FloGard® Plus Catch Basin Inserts**

FLAT GRATED CATCH BASINS				
	NOMINAL DIMENSIONS		PRODUCT UNIT PRICE	
	Minimum Inside Dimension	Maximum Inside Dimension	Standard Baskets (C1, C2, C4)	Stainless Baskets (C3)
Small	12" x 12"	21" x 21"	\$ 295.00	\$ 405.00
Medium	22" x 22"	24" x 36"	\$ 375.00	\$ 520.00
Large	30" x 36"	48" x 48"	\$ 765.00	\$ 880.00

CIRCULAR INLET CATCH BASINS				
	NOMINAL DIMENSIONS		PRODUCT UNIT PRICE	
	Minimum Inside Dimension	Maximum Inside Dimension	Standard Baskets (C1, C2, C4)	Stainless Baskets (C3)
Small	12" diameter	21" diameter	\$ 305.00	\$ 410.00
Large	22" diameter	36" diameter	\$ 495.00	\$ 620.00

COMBINATION INLET CATCH BASINS				
	NOMINAL DIMENSIONS		PRODUCT UNIT PRICE	
	Minimum Inside Dimension	Maximum Inside Dimension	Standard Baskets (C1, C2, C4)	Stainless Baskets (C3)
Small	12" x 12"	24" x 24"	\$ 345.00	\$ 460.00
Large	18"x 36"	36" x 36"	\$ 405.00	\$ 530.00

CURB INLET ONLY CATCH BASINS				
	NOMINAL DIMENSIONS		PRODUCT UNIT PRICE	
	Minimum Curb Opening	Maximum Curb Opening	Standard Baskets (C1, C2, C4)	Stainless Baskets (C3)
Small	2.0'	3.0'	\$ 325.00	\$ 430.00
Medium	3.1'	4.0'	\$ 415.00	\$ 535.00
Large	4.0'	7.0'	\$ 595.00	\$ 735.00

NOTES:

- (1) Actual dimensions will be field verified by KriStar prior to fabrication/installation
- (2) Products manufactured in accordance with Buy American contract provisions
- (3) Prices include manufacturer installation
- (4) Prices do not include any applicable sales taxes
- (4) The following discounts are available for volume purchases
 - 10-25 units Deduct \$10.00 per catch basin from above prices
 - More than 25 units Deduct \$25.00 per catch basin from above prices
- (5) Optional Items
 - (a) Fossil Rock Pouches @ \$15.00 per pouch
 - (b) Stainless Steel Trash and Debris Guards @ \$375.00 per each

Small Devices

KS-1

Combination Inlet Catch Basins

Device ID	Inside Dimensions	Price Stainless Baskets (C3) Per Unit
KS-1a	12 " x 12" - 24" x 24"	\$ 460.00
KS-1b	18"x 36" - 36" x 36"	\$ 530.00

KS-2(rect)

Flat Grated inlet style, Rectangular Inlet C3

Device ID	Inside Dimensions	Price Stainless Baskets (C3) Per Unit
KS-2a	12 " x 12" - 21" x 21"	\$405.00
KS-2b	22" x 22" - 24" x 36"	\$520.00
KS-2c	30" x 36" - 48" x 48"	\$880.00

KS-2(round)

Flat Grated inlet Style, Round Circular Inlet C3

Device ID	Inside Dimensions	Price Stainless Baskets (C3) Per Unit
KS-2d	12" - 21"	\$ 410.00
KS-2e	22" - 36"	\$ 620.00

NOTES:

- (1) Actual dimensions will be field verified by KriStar prior to fabrication/installation
- (2) Products manufactured in accordance with Buy American contract provisions
- (3) Prices include manufacturer installation
- (4) Prices do not include any applicable sales taxes
- (5) The following discounts are available for volume purchases
10-25 units Deduct \$10.00 per catch basin from above prices
More than 25 units Deduct \$25.00 per catch basin from above prices
- (6) Optional Items
 - (a) Fossil Rock Pouches @ \$15.00 per pouch
 - (b) Stainless Steel Trash and Debris Guards @ \$375.00 per each

KS-3

FlowGard Catch Basin Outlet Screen Insert

Device ID	Pipe Outlet Maximum Diameter	Unit Price
KS-3a	18"	\$ 795.00
KS-3b	24"	\$ 905.00
KS-3c	36"	\$995.00

- (1) Actual dimensions will be field verified by KriStar prior to fabrication and installation
- (2) Products manufactured in accordance with Buy American contract provisions
- (3) Prices include manufacturer installation

KS-7HF

FloGard Dual-Vortex Hydrodynamic Separator

Device ID	Unit Price
KS-7HF36	\$ 5,500.00
KS-7HF48	\$ 8,500.00
KS-7HF60	\$10,500.00
KS-7HF72	\$16,000.00
KS-7HF84	\$22,500.00
KS-7HF96	\$ 29,500.00
KS-7HF120	\$42,500.00
KS-7HF144	\$57,500.00

NOTES:

- (1) Actual dimensions will be field verified by KriStar prior to fabrication and installation
- (2) Products manufactured in accordance with Buy American contract provisions
- (3) Prices include circular or square pre-cast concrete structures, joint sealant, factory installed internal components and access cover assemblies.
- (4) Purchaser is responsible for offloading and setting of structures
- (4) Prices do not include any applicable sales taxes
- (5) There is no purchase quantity discount available for this product

KS-8HF

FloGard Perk Filter

Device ID	Unit Price
KS-8HF50	\$ 6,500.00
KS-8HF49	\$ 23,700.00
KS-8HF611	\$41,600.00
KS-8HF818	\$85,750.00

NOTES:

- (1) Actual dimensions will be field verified by KriStar prior to fabrication and installation
- (2) Products manufactured in accordance with Buy American contract provisions
- (3) Prices include precast concrete components, bolted, gasketed lids, factory-installed internal components and delivery to jobsite
- (4) Purchaser is responsible for offloading and setting of structures
- (4) Prices do not include any applicable sales taxes
- (5) There is no purchase quantity discount available for this product

KS-9HF

FloGard Swirl-Flo Screen Separator

Device ID	Nominal Manhole Diameter	Unit Price
KS-9HF48	48"	\$ 3,650.00
KS-9HF60	60"	\$ 5,495.00
KS-9HF96	96"	\$14,950.00

NOTES:

- (1) Actual dimensions will be field verified by KriStar prior to fabrication and installation
- (2) Products manufactured in accordance with Buy American contract provisions
- (3) Prices include precast concrete components, bolted, gasketed lids, factory-installed internal components and delivery to jobsite
- (4) Purchaser is responsible for offloading and setting of structures
- (5) Prices do not include any applicable sales taxes
- (6) There is no purchase quantity discount available for this product

KS-10HF

Nettech Gross Pollutant Trap- In Line

Device ID	Nominal Pipe Diameter	Unit Price
KS-10HF _s	12"-24"	\$ 5,950.00
KS-10HF _m	30"-48"	\$ 8,950.00
KS-10HF _I	54"-72"	\$15,950.00

- (1) Actual dimensions will be field verified by KriStar prior to fabrication and installation
- (2) Products manufactured in accordance with Buy American contract provisions
- (3) Prices include manufacturer installation for interior or flange mount
- (4) Prices do not include any applicable sales taxes
- (5) There are no quantity purchase discounts available for this item

KS-11HF

Nettech Gross Pollutant Trap- End of Line

Device ID	Nominal Pipe Diameter	Unit Price
KS-11HF _s	12"-24"	\$ 5,950.00
KS-11HF _m	30"-48"	\$ 8,950.00
KS-11HF _I	54"-72"	\$15,950.00

- (1) Actual dimensions will be field verified by KriStar prior to fabrication and installation
- (2) Products manufactured in accordance with Buy American contract provisions
- (3) Prices include manufacturer installation for interior or flange mount
- (4) Prices do not include any applicable sales taxes
- (5) There are no quantity purchase discounts available for this item

Catchbasin Insert, Full Capture Device

KS-1 Flo Gard Plus catchbasin filter Inserts, combination inlet style, stainless steel only (C3)
Drop in Basket

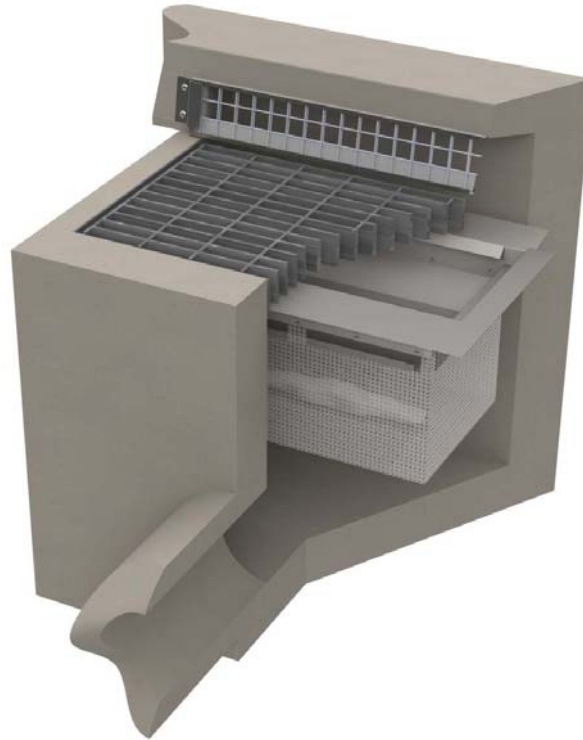

<p>Company Contact: KriStar Enterprises, Inc., Santa Rosa, CA Sales contact: Sue Lillo, 800-579-8819 slillo@kristar.com http://www.kristar.com</p>	<p>Meets San Francisco Bay Water Board full capture specifications</p>
<p>Storage capacity: 1.8, 2.7 or 4.1 cubic feet depending on size of inlet</p>	<p>Replacement Parts: Available</p>
<p>Vendor's maintenance estimate: "Depends on the amount of runoff, pollutant loading and interference from debris"</p>	<p>Warranty: 5 years</p>
<p>Material: 304 stainless steel</p>	<p>Delivery Time: Typically 1 week for standard products; 3 weeks for customized products</p>
<p>Pricing: See over.</p>	
<p>Installed: FloGard inserts are in use in County of Sonoma, Alameda County Transit, Santa Clara Valley Transit Authority, Riverside County-TLMA</p>	

Only the stainless steel version of this device is accepted in the project.

No reference information was available for this device

Bay Area-wide Trash Capture Demonstration Project

Funded by the Clean Water State Revolving Fund and the American Recovery and Reinvestment Act



Bay Area-wide Trash Capture Demonstration Project

Appendix B- Item Q Pricing Schedule

Name of Proposing Company: KriStar Enterprises, Inc.

Name of Device: FloGard® Plus Catch Basin Inserts

FLAT GRATED CATCH BASINS				
	NOMINAL DIMENSIONS		PRODUCT UNIT PRICE	
	Minimum Inside Dimension	Maximum Inside Dimension	Standard Baskets (C1, C2, C4)	Stainless Baskets (C3)
Small	12 " x 12"	21" x 21"	\$ 295.00	\$ 405.00
Medium	22" x 22"	24" x 36"	\$ 375.00	\$ 520.00
Large	30" x 36"	48" x 48"	\$ 765.00	\$ 880.00

CIRCULAR INLET CATCH BASINS				
	NOMINAL DIMENSIONS		PRODUCT UNIT PRICE	
	Minimum Inside Dimension	Maximum Inside Dimension	Standard Baskets (C1, C2, C4)	Stainless Baskets (C3)
Small	12 " diameter	21" diameter	\$ 305.00	\$ 410.00
Large	22" diameter	36" diameter	\$ 495.00	\$ 620.00

COMBINATION INLET CATCH BASINS				
	NOMINAL DIMENSIONS		PRODUCT UNIT PRICE	
	Minimum Inside Dimension	Maximum Inside Dimension	Standard Baskets (C1, C2, C4)	Stainless Baskets (C3)
Small	12 " x 12"	24" x 24"	\$ 345.00	\$ 460.00
Large	18" x 36"	36" x 36"	\$ 405.00	\$ 530.00

CURB INLET ONLY CATCH BASINS				
	NOMINAL DIMENSIONS		PRODUCT UNIT PRICE	
	Minimum Curb Opening	Maximum Curb Opening	Standard Baskets (C1, C2, C4)	Stainless Baskets (C3)
Small	2.0'	3.0'	\$ 325.00	\$ 430.00
Medium	3.1'	4.0'	\$ 415.00	\$ 535.00
Large	4.0'	7.0'	\$ 595.00	\$ 735.00

NOTES:

(1) Actual dimensions will be field verified by KriStar prior to fabrication/installation

(2) Products manufactured in accordance with Buy American contract provisions

(3) Prices include manufacturer installation

(4) Prices do not include any applicable sales taxes

(4) The following discounts are available for volume purchases

10-25 units Deduct \$10.00 per catch basin from above prices

More than 25 units Deduct \$25.00 per catch basin from above prices

(5) Optional Items (a) Fossil Rock Pouches @ \$15.00 per pouch

(b) Stainless Steel Trash and Debris Guards @ \$375.00 per each

Small Devices

KS-1

Combination Inlet Catch Basins

Device ID	Inside Dimensions	Price Stainless Baskets (C3) Per Unit
KS-1a	12 " x 12" - 24" x 24"	\$ 460.00
KS-1b	18"x 36" - 36" x 36"	\$ 530.00

KS-2(rect)

Flat Grated inlet style, Rectangular Inlet C3

Device ID	Inside Dimensions	Price Stainless Baskets (C3) Per Unit
KS-2a	12 " x 12" - 21" x 21"	\$405.00
KS-2b	22" x 22" - 24" x 36"	\$520.00
KS-2c	30" x 36" - 48" x 48"	\$880.00

KS-2(round)

Flat Grated inlet Style, Round Circular Inlet C3

Device ID	Inside Dimensions	Price Stainless Baskets (C3) Per Unit
KS-2d	12" - 21"	\$ 410.00
KS-2e	22" - 36"	\$ 620.00

NOTES:

- (1) Actual dimensions will be field verified by KriStar prior to fabrication/installation
- (2) Products manufactured in accordance with Buy American contract provisions
- (3) Prices include manufacturer installation
- (4) Prices do not include any applicable sales taxes
- (5) The following discounts are available for volume purchases
10-25 units Deduct \$10.00 per catch basin from above prices
More than 25 units Deduct \$25.00 per catch basin from above prices
- (6) Optional Items
 - (a) Fossil Rock Pouches @ \$15.00 per pouch
 - (b) Stainless Steel Trash and Debris Guards @ \$375.00 per each

KS-3

FlowGard Catch Basin Outlet Screen Insert

Device ID	Pipe Outlet Maximum Diameter	Unit Price
KS-3a	18"	\$ 795.00
KS-3b	24"	\$ 905.00
KS-3c	36"	\$995.00

- (1) Actual dimensions will be field verified by KriStar prior to fabrication and installation
- (2) Products manufactured in accordance with Buy American contract provisions
- (3) Prices include manufacturer installation

Catchbasin Insert, Full Capture Device

GFI-1 "Wavy" Grate Trash Catcher

Connector pipe screen; option for use with curb inlet catchbasins (add'l cost)



<p>Company Contact: Gentile Family Industries (Waterway Solutions) Sales contact: Gail Brice, 562-592-5989 gail.brice@waterwaysolution.com www.waterwaysolution.com</p>	<p>Certified full capture by LA Regional Water Board Meets San Francisco Bay Water Board full capture specifications</p>
<p>Storage capacity: "For a 24" x 24" x 24" catchbasin, trash storage capacity will be 3.46 cubic feet of trash."</p>	<p>Replacement Parts: Available</p>
<p>Vendor's maintenance estimate: Routine trash removal & cleaning of deflector screen w/wire brush</p>	<p>Warranty: 5 yrs</p>
<p>Material: Marine-grade 316 stainless steel</p>	<p>Delivery Time: "45 days from initial order. Once inventory is in place, maximum of two weeks to installation."</p>
<p>Pricing: See over.</p>	

Comments from reference checks

Device effectiveness in capturing trash

Good ratings for installation process and durability

Other

Good customer service

"Installations in locations where street slope is in excess of 5% will need to be evaluated to determine if standard design is appropriate"

Bay Area-wide Trash Capture Demonstration Project

Funded by the Clean Water State Revolving Fund and the American Recovery and Reinvestment Act

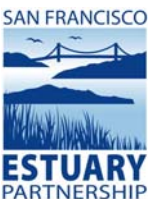

Gentile Family Industries – (Waterway Solutions)

SMALL CATCH BASINS < 36" DEEP

WAVY Grate Trash Catcher – Vendor Model GFI-1-GS (Grated Inlet)

Device ID	Number of Devices	Price per Unit (Includes Installation)
GFI-1GS	10-49	\$399.00
GFI-1GS	50-99	\$375.00
GFI-1GS	100-499	\$365.00
GFI-1GS	500-999	\$349.00
GFI-1GS	1000-2499	\$330.00
GFI-1GS	2499-5000+	\$299.00

Note: Orders of less than 10 units will be charged a minimum of \$4800.00

WAVY Grate Trash Catcher – Vendor Model GFI-1-CS (Curb Inlet)

Device ID	Number of Devices	Price per Unit (Includes Installation)
GFI-1CS	10-49	\$399.00
GFI-1CS	50-99	\$375.00
GFI-1CS	100-499	\$365.00
GFI-1CS	500-999	\$349.00
GFI-1CS	1000-2499	\$330.00
GFI-1CS	2499-5000+	\$299.00

Note: Orders of less than 10 units will be charged a minimum of \$4800.00

MEDIUM CATCH BASINS (36" – 60" Deep)

WAVY Grate Trash Catcher – Vendor Model GFI-1-GM (Grated Inlet)

Device ID	Number of Devices	Price per Unit (Includes Installation)
GFI-1GM	10-49	\$440.00
GFI-1GM	50-99	\$425.00
GFI-1GM	100-499	\$415.00
GFI-1GM	500-999	\$410.00
GFI-1GM	1000-2499+	\$375.00

Note: Orders of less than 10 units will be charged a minimum of \$4800.00

WAVY Grate Trash Catcher – Vendor Model GFI-1-CM (Curb Inlet)

Device ID	Number of Devices	Price per Unit (Includes Installation)
GFI-1CM	10-49	\$440.00
GFI-1CM	50-99	\$425.00
GFI-1CM	100-499	\$415.00
GFI-1CM	500-999	\$410.00
GFI-1CM	1000-2499+	\$375.00

Note: Orders of less than 10 units will be charged a minimum of \$4800.00

LARGE CATCH BASINS (61" – 96" Deep)

WAVY Grate Trash Catcher – Vendor Model GFI-1-GL (Grated Inlet)

Device ID	Number of Devices	Price per Unit (Includes Installation)
GFI-1GL	10-49	\$485.00
GFI-1GL	50-99	\$475.00
GFI-1GL	100-499	\$460.00
GFI-1GL	500-999	\$455.00
GFI-1GL	1000-2499	\$445.00
GFI-1GL	2499-5000+	\$425.00

Note: Orders of less than 10 units will be charged a minimum of \$4800.00

WAVY Grate Trash Catcher – Vendor Model GFI-1-CL (Curb Inlet)

Device ID	Number of Devices	Price per Unit (Includes Installation)
GFI-1CL	10-49	\$485.00
GFI-1CL	50-99	\$475.00
GFI-1CL	100-499	\$460.00
GFI-1CL	500-999	\$455.00
GFI-1CL	1000-2499	\$445.00
GFI-1CL	2499-5000+	\$425.00

Note: Orders of less than 10 units will be charged a minimum of \$4800.00

Curb Inlet Screens

ARS- Automatic Retractable Screen – Vendor Model GFI TS (1 thru 6)

Device ID	Curb Opening Length	Vendor Model Number	Price per Unit (Includes Installation)
GFI-2TS1	<5 feet	GFI-2-TS-1	\$360.00
GFI-2TS2	5-10 feet	GFI-2-TS-2	\$425.00
GFI-2TS3	10-15 feet	GFI-2-TS-3	\$905.00
GFI-2TS4	15-20 feet	GFI-2-TS-4	\$1235.00
GFI-2TS5	20-25 feet	GFI-2-TS-5	\$1525.00
GFI-2TS6	25-30 feet	GFI-2-TS-6	\$2100.00

Note: Minimum order \$3600.00. 10% Discount for order of 100+ ARS devices.

Catchbasin Insert, Full Capture Device

G2-1, G2-1R Collector Pipe Screen, Collector Pipe Screen (Removable) Connector pipe screen

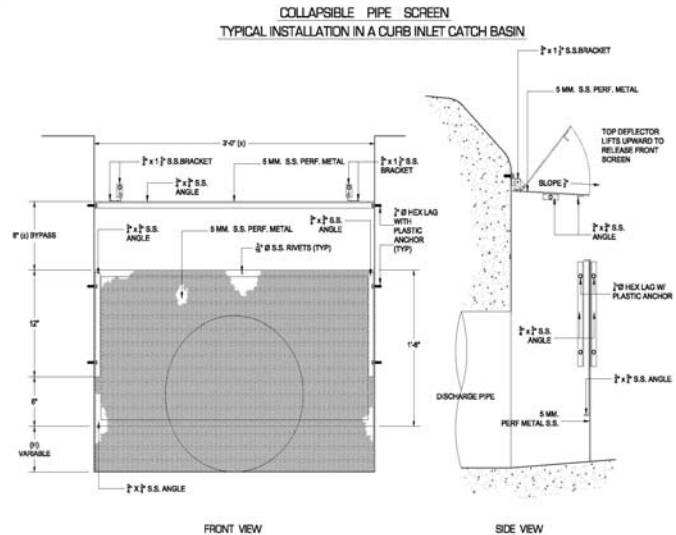
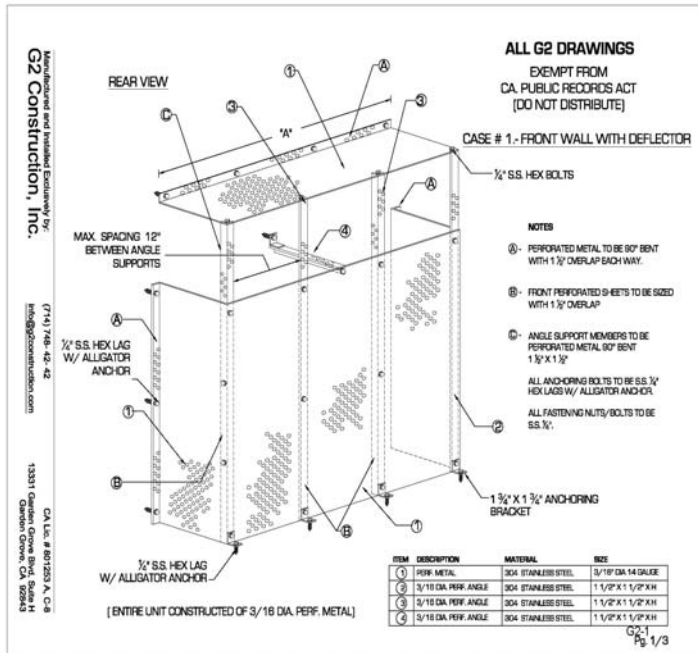

Manufactured and Installed Exclusively by:
G-2 Construction, Inc.
(714) 748-4242
info@g2construction.com
CA Lic. # B01263 A, C-B
13331 Garden Grove Blvd, Suite H
Garden Grove, CA 92643

<p>Company Contact: G2 Construction, Inc., Garden Grove, CA Sales contact: John R. Alvarado, 714-448-8080 jalvarado@g2construction.com http://g2construction.com</p>	<p>Certified full capture by LA Regional Water Board Meets San Francisco Bay Water Board full capture specifications</p>
<p>Storage capacity: depends on size of catchbasin</p>	<p>Replacement Parts: Available</p>
<p>Vendor's maintenance estimate: Clogged device requires 5-10 minutes to clean depending on size</p>	<p>Warranty: 1 yr workmanship/3 yrs parts+materials</p>
<p>Material: stainless steel 304 grade</p>	<p>Delivery Time: "G2 can provide product and installation within 10 working days of ordering"</p>
<p>Pricing: See over.</p>	

Comments from reference checks

Device effectiveness in capturing trash

All screens collected trash effectively. Some minor problems with mud getting into the catch basins but otherwise the screens performed well.

Maintenance issues/experience

Make sure the bypass of the water is the size appropriate for the inlet and screen device. Sharp edges on the screen are a hazard to municipal workers. Installation of screens was within the time specified by the vendor.

Other

Reference was satisfied with the vendor's customer service.

Bay Area-wide Trash Capture Demonstration Project

Funded by the Clean Water State Revolving Fund and the American Recovery and Reinvestment Act



SFBA - G2 Removable "CPS"

Collector Pipe Screen Pricing Scale

These removable units are designed for the 2'x3' grates inlets around the Bay Area.

Qty. Units	Cost Per unit
100 - 500	\$475.00
501- 1500	\$450.00
1501 - 3500	\$425.00
3501 +	\$400.00

Notes; Pricing does not include catch basin cleaning
Pricing does not include permits or fees
Pricing does include product and installation at prevailing wages.
Pricing does not include hydraulic sizing analysis for device sizing.

This is a Stainless Steel 5mm perforated screen installed with approved plastic anchors and stainless steel hardware.

Our device is modeled after L.A. County designs and parameters.
New parameters or minimum device sizing will have to be determined by local agencies prior to installation.

Pricing to remain in effect for 2 years from bid due date.

G2-1 “CPS” Connector Pipe Screen

Device ID	Quantity	Price per Unit
G2-1	30-100	\$475.00
G2-1	101-500	\$450.00
G2-1	501-1000	\$390.00
G2-1	1001 +	\$350.00

Note: Pricing does not include catch basin cleaning
Pricing does not include permits or fees
Pricing does include product and installation at prevailing wages
Pricing does not include hydraulic sizing analysis for device sizing

This is a stainless steel 5mm perforated screen installed with approved Plastic anchors and stainless steel hardware.

Our device is modeled after L.A. County designs and parameters.
New parameters or minimum device sizing will have to be determined by local agencies prior to installation.

Pricing to remain in effect for 2 years from bid due date.

G2-1R “Removable CPS” Connector Pipe Screen

Device ID	Quantity	Price per Unit
G2-1R	30-100	\$475.00
G2-1R	101-500	\$450.00
G2-1R	501-1000	\$425.00
G2-1R	1001 +	\$400.00

Note: Pricing does not include catch basin cleaning
Pricing does not include permits or fees
Pricing does include product and installation at prevailing wages
Pricing does not include hydraulic sizing analysis for device sizing

This is a stainless steel 5mm perforated screen installed with approved Plastic anchors and stainless steel hardware.

Our device is modeled after L.A. County designs and parameters.
New parameters or minimum device sizing will have to be determined by local agencies prior to installation.

Pricing to remain in effect for 2 years from bid due date.

Catchbasin Insert, Full Capture Device

G2-1, G2-1R Collector Pipe Screen, Collector Pipe Screen (Removable) Connector pipe screen

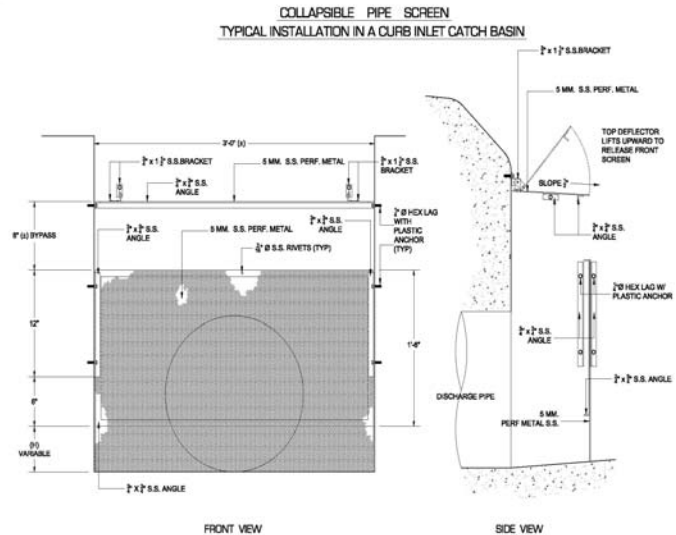
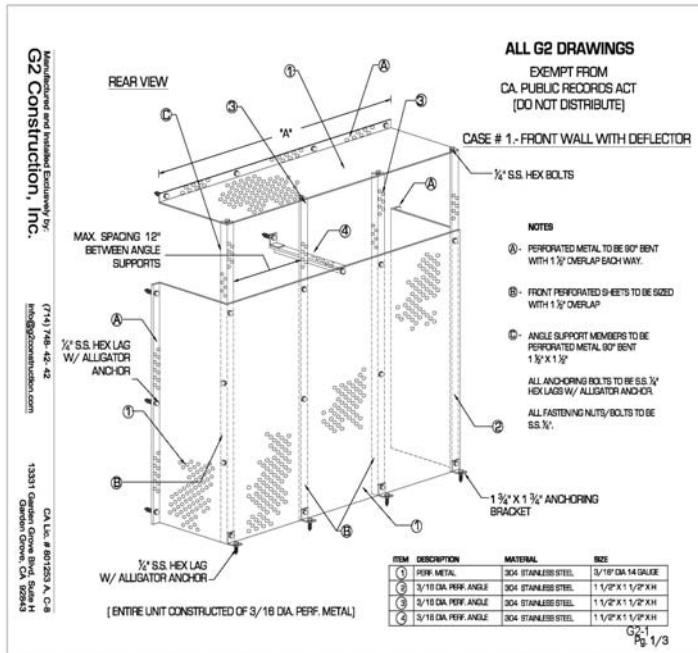

Manufactured and Installed Exclusively by:
G-2 Construction, Inc.
(714) 748-4242
info@g2construction.com
13331 Garden Grove Blvd, Suite H
Garden Grove, CA 92643
CA Lic. # 801263 A, C-B

<p>Company Contact: G2 Construction, Inc., Garden Grove, CA Sales contact: John R. Alvarado, 714-448-8080 jalvarado@g2construction.com http://g2construction.com</p>	<p>Certified full capture by LA Regional Water Board Meets San Francisco Bay Water Board full capture specifications</p>
<p>Storage capacity: depends on size of catchbasin</p>	<p>Replacement Parts: Available</p>
<p>Vendor's maintenance estimate: Clogged device requires 5-10 minutes to clean depending on size</p>	<p>Warranty: 1 yr workmanship/3 yrs parts+materials</p>
<p>Material: stainless steel 304 grade</p>	<p>Delivery Time: "G2 can provide product and installation within 10 working days of ordering"</p>
<p>Pricing: See over.</p>	

Comments from reference checks

Device effectiveness in capturing trash

All screens collected trash effectively. Some minor problems with mud getting into the catch basins but otherwise the screens performed well.

Maintenance issues/experience

Make sure the bypass of the water is the size appropriate for the inlet and screen device. Sharp edges on the screen are a hazard to municipal workers. Installation of screens was within the time specified by the vendor.

Other

Reference was satisfied with the vendor's customer service.

Bay Area-wide Trash Capture Demonstration Project

Funded by the Clean Water State Revolving Fund and the American Recovery and Reinvestment Act



SFBA "CPS" Collector Pipe Screen Pricing Scale

Qty. Units	Cost Per unit
100 - 500	\$500.00
501- 1500	\$445.00
1501 - 3500	\$390.00
3501 +	\$350.00

Notes; Pricing does not include catch basin cleaning
Pricing does not include permits or fees
Pricing does include product and installation at prevailing wages.
Pricing does not include hydraulic sizing analysis for device sizing.

This is a Stainless Steel 5mm perforated screen installed with approved plastic anchors and stainless steel hardware.

Our device is modeled after L.A. County designs and parameters.
New parameters or minimum device sizing will have to be determined by local agencies prior to installation.

Pricing to remain in effect for 2 years from bid due date.

G2-1 “CPS” Connector Pipe Screen

Device ID	Quantity	Price per Unit
G2-1	30-100	\$475.00
G2-1	101-500	\$450.00
G2-1	501-1000	\$390.00
G2-1	1001 +	\$350.00

Note: Pricing does not include catch basin cleaning
Pricing does not include permits or fees
Pricing does include product and installation at prevailing wages
Pricing does not include hydraulic sizing analysis for device sizing

This is a stainless steel 5mm perforated screen installed with approved Plastic anchors and stainless steel hardware.

Our device is modeled after L.A. County designs and parameters.
New parameters or minimum device sizing will have to be determined by local agencies prior to installation.

Pricing to remain in effect for 2 years from bid due date.

G2-1R “Removable CPS” Connector Pipe Screen

Device ID	Quantity	Price per Unit
G2-1R	30-100	\$475.00
G2-1R	101-500	\$450.00
G2-1R	501-1000	\$425.00
G2-1R	1001 +	\$400.00

Note: Pricing does not include catch basin cleaning
Pricing does not include permits or fees
Pricing does include product and installation at prevailing wages
Pricing does not include hydraulic sizing analysis for device sizing

This is a stainless steel 5mm perforated screen installed with approved Plastic anchors and stainless steel hardware.

Our device is modeled after L.A. County designs and parameters.
New parameters or minimum device sizing will have to be determined by local agencies prior to installation.

Pricing to remain in effect for 2 years from bid due date.

Catchbasin Insert, Full Capture Device

ECI-1 Debris Dam Connector pipe screen

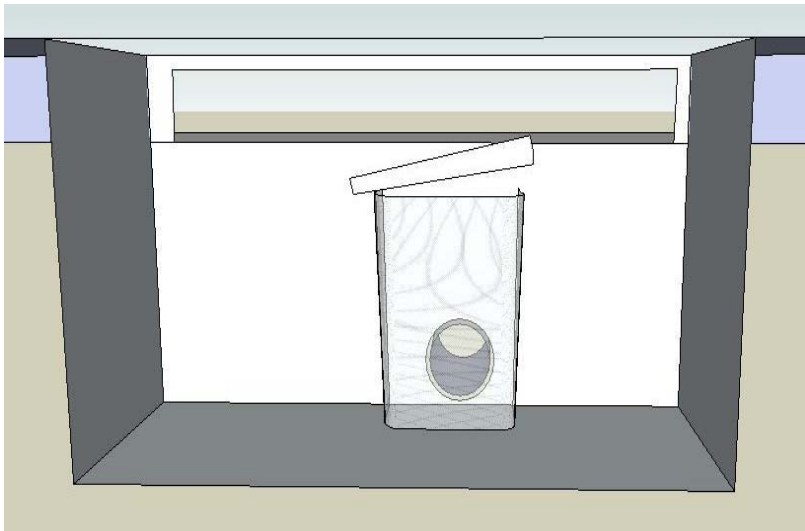

<p>Company Contact: Ecology Control Industries (American Stormwater), Torrance, CA Sales contact: Todd Waters, 310-354-9999 x284 twaters@ecologycontrol.com http://www.ecologycontrol.com</p>	<p>Meets San Francisco Bay Water Board full capture specifications</p>
<p>Storage capacity: Depends on size of catchbasin</p>	<p>Replacement Parts: Available</p>
<p>Vendor's maintenance estimate: Remove trash when at least 40% full</p>	<p>Warranty: 1 yr workmanship/3 yrs parts+materials</p>
<p>Material: Series 304 stainless steel, 14 & 16 gauge</p>	<p>Delivery Time: Estimated delivery/installation time from receipt of order can range from 2 to 4 weeks depending on quantity</p>
<p>Pricing: See over.</p>	

Comments from reference checks

Device effectiveness in capturing trash

Reference satisfied with trash capture

Maintenance issues/experience

Inspection necessary after every significant storm

Bay Area-wide Trash Capture Demonstration Project

Funded by the Clean Water State Revolving Fund and the American Recovery and Reinvestment Act

Price including price breaks or discounts for quantity orders. Price should include installation. Prices shall remain in effect for two years from contract execution. (Attach extra sheets or a detailed price list or spreadsheet as appropriate).

Options and/or exclusions; alternate prices dependent on the scope of work at a specific location: All work or devices not described within the RFP, will be quoted on a case by case basis.

Price Sheet

Item No.		Unit of Measure	Approx. Quantity	Automatic Retractable Curb Screens (ARS) Pricing	100% Full Capture Insert	
6	Furnish & Install Full Capture Insert	EA	N/A		\$375.00	

Ecology Control Industries (American Stormwater)

ECI-1 Debris Dam

Device ID	Price per Unit
ECI-1	\$375.00

ECI-2 Surfgate (Automatic Retractable Screen)

Device ID	Size	# of Screens	Price per Unit
ECI-2a	0-5'	1	\$395.00
ECI-2b	5'-8'	2	\$770.00
ECI-2c	8'-15'	3-4	\$1190.00
ECI-2d	15'-22'	4-5	\$1590.00
ECI-2e	22'-29'	5	\$2500.00

Catchbasin Insert, Full Capture Device

BC-4 Trash Guard

Plastic (HDPE) catchbasin connector pipe screen.
3 standard sizes

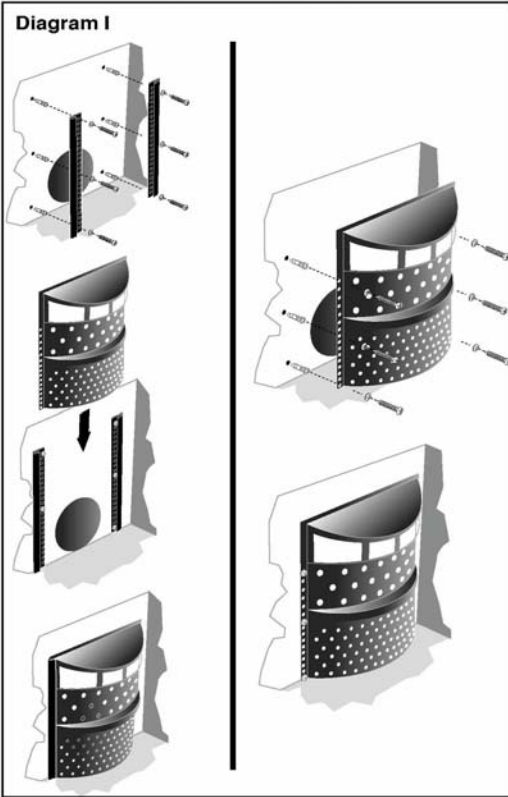

<p>Company Contact: Bio Clean Environmental Services, Inc., Oceanside, CA Sales contacts: Greg Kent, (760) 433-7640 or Kirk Vallejo, (760) 681-9583 gkent@biocleanenvironmental.net kvallejo@biocleanenvironmental.net http://www.biocleanenvironmental.com</p>	<p>Meets San Francisco Bay Water Board full capture specifications</p>
<p>Storage capacity: depends on size of catchbasin</p>	<p>Replacement Parts: Available</p>
<p>Vendor's maintenance estimate: Between May 1 and Sept. 30, clean filter when over 40% full</p>	<p>Warranty: 1 yr</p>
<p>Material: High-density polyethylene</p>	<p>Delivery Time: 50 or fewer 4 weeks; 50-100 6 weeks; 100-250 10 weeks; call for more than 250</p>
<p>Pricing: See over. Have uninstalled price. Traffic control not included in pricing</p>	

No reference information available

Bay Area-wide Trash Capture Demonstration Project

Funded by the Clean Water State Revolving Fund and the American Recovery and Reinvestment Act



TrashGuard

Table 2

Prices for California "Full Trash Capture" TrashGuard Price Includes Installation

Size Range	Price per System Installed - 1 to 25	Price per System Installed - 26 to 99	Price Per System - 100 to 499	Price Per System Installed 500 to 999	Price Per System Installed 1000 +
23"	\$540.00	\$506.00	\$484.00	\$476.00	\$468.00
28"	\$565.00	\$529.00	\$505.00	\$497.00	\$489.00
34"	\$637.00	\$597.00	\$569.00	\$560.00	\$550.00

Prices for California "Full Trash Capture" TrashGuard Price Includes Installation and Vendor Measure

Size Range	Price per System Installed 1 to 25	Price per System Installed 26 to 99	Price per System Installed 100 to 499	Price per System Installed 500 to 999	Price per System Installed 1000 +
23"	\$575.00	\$541.00	\$519.00	\$511.00	\$503.00
28"	\$600.00	\$564.00	\$540.00	\$532.00	\$524.00
34"	\$672.00	\$623.00	\$604.00	\$595.00	\$585.00

Catch Basins Must Be Cleaned Prior To Installation

Installation is Based Upon Prevailing Rates

Distributed Exclusively by Bio Clean Environmental Services, Inc

US Patent # 7276156

1 Year Warranty



Southern California
2972 San Lus Rey Rd.
Oceanside, CA 92058
Phone 760-433-7640

Northern California
690 Sunlow St.
San Jose, CA 95126
Phone 760-579-1584

The preceding information is confidential. It is not intended for transmission to, or receipt by, any unauthorized persons. If you have received this message in error, please (i) do not read it, (ii) reply to the sender that you received the fax and following information in error, and (iii) erase or destroy the message. Information contained in the preceding pages is solely for the recipient addressed in this cover letter. This fax (including all following pages) contains confidential information intended for the specific individual named above and the firm that person represents. This information has been provided in privacy and is protected by law. If you are not the intended recipient, you should delete this message. Any disclosure, copying, or distribution of any information, especially pricing, is strictly prohibited. Any distribution of this information is illegal unless approved by Bio Clean Environmental Services, Inc.

BC-4**Prices for California "Full Trash Capture" TrashGard
Price Includes Installation (without Vendor Measure)**

Device ID	Size Range	Size Range Price per System Installed - 1 to 25	Price per System Installed 26 to 99	Price Per System - Installed 100 to 499	Price Per System Installed 500 to 999	Price Per System Installed 1000 +
BC-4a	23"	\$540.00	\$506.00	\$484.00	\$476.00	\$468.00
BC-4b	28"	\$565.00	\$529.00	\$505.00	\$497.00	\$489.00
BC-4c	34"	\$637.00	\$597.00	\$569.00	\$560.00	\$550.00

**Prices for California "Full Trash Capture" TrashGard
Price Includes Installation and Vendor Measure**

Device ID	Size Range	Price per System Installed 1 to 25	Price per System Installed 26 to 99	Price per System Installed 100 to 499	Price per System Installed 500 to 999	Price per System Installed 1000 +
BC-4d	23"	\$575.00	\$541.00	\$519.00	\$511.00	\$503.00
BC-4e	28"	\$600.00	\$564.00	\$540.00	\$532.00	\$524.00
BC-4f	34"	\$672.00	\$623.00	\$604.00	\$595.00	\$585.00

Catchbasin Insert, Full Capture Device

BC-3 Modular Connector Pipe Screen Catchbasin connector pipe screen (CPS), removable



<p>Company Contact: Bio Clean Environmental Services, Inc., Oceanside, CA Sales contacts: Greg Kent, (760) 433-7640 or Kirk Vallejo, (760) 681-9583 gkent@biocleanenvironmental.net kvallejo@biocleanenvironmental.net http://www.biocleanenvironmental.com</p>	<p>Certified full capture by LA Regional Water Board Meets San Francisco Bay Water Board full capture specifications</p>
<p>Storage capacity: depends on size of catchbasin</p>	<p>Replacement Parts: Available</p>
<p>Vendor's maintenance estimate: Between May 1 and Sept. 30, clean filter when over 40% full</p>	<p>Warranty: 5 yrs</p>
<p>Material: Type 316 stainless steel</p>	<p>Delivery Time: 50 or fewer 4 weeks; 50-100 6 weeks; 100-250 10 weeks; call for more than 250</p>
<p>Pricing: See over. Have uninstalled price. Traffic control not included in pricing</p>	

No reference information available

Bay Area-wide Trash Capture Demonstration Project

Funded by the Clean Water State Revolving Fund and the American Recovery and Reinvestment Act

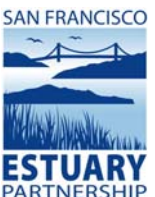

BIO CLEAN MODULAR CPS

TABLE 2

Prices Include Installation

Size	Price per System Installed	Price per System Installed - Vendor Measure	Discounted Price Installed - 50 to 200 units	Discounted Price Installed - 50 to 200 - Vendor Measure	Discounted Price Installed 200 Plus	Discounted Price Installed 200 Plus - Vendor Measure
26" Wide x 12" Tall	\$409.00	\$474.00	\$389.00	\$449.00	\$404.00	\$454.00
26" Wide x 18" Tall	\$656.00	\$721.00	\$685.00	\$745.00	\$670.00	\$720.00
26" Wide x 24" Tall	\$728.00	\$793.00	\$753.00	\$813.00	\$731.00	\$781.00
26" Wide x 30" Tall	\$975.00	\$1,040.00	\$988.00	\$1,048.00	\$943.00	\$993.00
26" wide x 36" Tall	\$1,047.00	\$1,112.00	\$1,056.00	\$1,116.00	\$1,004.00	\$1,054.00
32" Wide x 12" Tall	\$503.00	\$568.00	\$539.00	\$599.00	\$539.00	\$589.00
32" Wide x 18" Tall	\$820.00	\$885.00	\$840.00	\$900.00	\$810.00	\$860.00
32" Wide x 24" Tall	\$906.00	\$971.00	\$922.00	\$982.00	\$883.00	\$933.00
32" Wide x 30" Tall	\$1,243.00	\$1,308.00	\$1,242.00	\$1,302.00	\$1,171.00	\$1,221.00
32" wide x 36" Tall	\$1,329.00	\$1,394.00	\$1,324.00	\$1,384.00	\$1,245.00	\$1,295.00
36" Wide x 12" Tall	\$525.00	\$590.00	\$560.00	\$620.00	\$558.00	\$608.00
36" Wide x 18" Tall	\$868.00	\$933.00	\$886.00	\$946.00	\$851.00	\$901.00
36" Wide x 24" Tall	\$960.00	\$1,025.00	\$973.00	\$1,033.00	\$929.00	\$979.00
36" Wide x 30" Tall	\$1,293.00	\$1,358.00	\$1,240.00	\$1,350.00	\$1,215.00	\$1,301.00
36" wide x 36" Tall	\$1,400.00	\$1,465.00	\$1,391.00	\$1,451.00	\$1,305.00	\$1,355.00
42" Wide x 12" Tall	\$639.00	\$704.00	\$668.00	\$728.00	\$655.00	\$705.00
42" Wide x 18" Tall	\$1,042.00	\$1,107.00	\$1,051.00	\$1,111.00	\$999.00	\$1,049.00
42" Wide x 24" Tall	\$1,148.00	\$1,213.00	\$1,152.00	\$1,212.00	\$1,090.00	\$1,140.00
42" Wide x 30" Tall	\$1,551.00	\$1,616.00	\$1,535.00	\$1,595.00	\$1,435.00	\$1,485.00
42" wide x 36" Tall	\$1,657.00	\$1,722.00	\$1,635.00	\$1,695.00	\$1,525.00	\$1,575.00
48" Wide x 12" Tall	\$671.00	\$736.00	\$699.00	\$759.00	\$683.00	\$733.00
48" Wide x 18" Tall	\$1,080.00	\$1,146.00	\$1,088.00	\$1,148.00	\$1,033.00	\$1,083.00
48" Wide x 24" Tall	\$1,192.00	\$1,257.00	\$1,194.00	\$1,254.00	\$1,128.00	\$1,178.00
48" Wide x 30" Tall	\$1,601.00	\$1,666.00	\$1,582.00	\$1,642.00	\$1,477.00	\$1,527.00
48" wide x 36" Tall	\$1,713.00	\$1,778.00	\$1,689.00	\$1,749.00	\$1,574.00	\$1,624.00

Catch Basins Must Be Cleaned Prior To Installation

Installation is Based Upon Prevailing Wage Rates

5 Year Warranty



Southern California
 2972 San Lus Rey Rd.
 Oceanside, CA 92058
 Phone 760-433-7640

Northern California
 690 Sunlow St.
 San Jose, CA 95126
 Phone 760-579-1584

The preceding information is confidential. It is not intended for transmission to, or receipt by, any unauthorized persons. If you have received this message in error, please (i) do not read it, (ii) reply to the sender that you received the fax and following information in error, and (iii) erase or destroy the message. Information contained in the preceding pages is solely for the recipient addressed in this cover letter. This fax (including all following pages) contains confidential information intended for the specific individual named above and the firm that person represents. This information has been provided in privacy and is protected by law. If you are not the intended recipient, you should delete this message. Any disclosure, copying, or distribution of any information, especially pricing, is strictly prohibited. Any distribution of this information is illegal unless approved by Bio Clean Environmental Services, Inc.

BC-3**Prices Include Installation**

Device ID	Size	Size Price per System Installed	Price per System Installed - Vendor Measure	Discounted Price Installed - 50 to 200 units	Discounted Price Installed - 50 to 200 - Vendor Measure	Discounted Price Installed 200 Plus	Discounted Price Installed 200 Plus - Vendor Measure
BC-3a	26" Wide x 12" Tall	\$409.00	\$474.00	\$389.00	\$449.00	\$404.00	\$454.00
BC-3b	26" Wide x 18" Tall	\$656.00	\$721.00	\$685.00	\$745.00	\$670.00	\$720.00
BC-3c	26" Wide x 24" Tall	\$728.00	\$793.00	\$753.00	\$813.00	\$731.00	\$781.00
BC-3d	26" Wide x 30" Tall	\$975.00	\$1,040.00	\$988.00	\$1,048.00	\$943.00	\$993.00
BC-3e	26" wide x 36" Tall	\$1,047.00	\$1,112.00	\$1,056.00	\$1,116.00	\$1,004.00	\$1,054.00
BC-3f	32" Wide x 12" Tall	\$503.00	\$568.00	\$539.00	\$599.00	\$539.00	\$589.00
BC-3g	32" Wide x 18" Tall	\$820.00	\$885.00	\$840.00	\$900.00	\$810.00	\$860.00
BC-3h	32" Wide x 24" Tall	\$906.00	\$971.00	\$922.00	\$982.00	\$883.00	\$933.00
BC-3i	32" Wide x 30" Tall	\$1,243.00	\$1,308.00	\$1,242.00	\$1,302.00	\$1,171.00	\$1,221.00
BC-3j	32" wide x 36" Tall	\$1,329.00	\$1,394.00	\$1,324.00	\$1,384.00	\$1,245.00	\$1,295.00
BC-3k	36" Wide x 12" Tall	\$525.00	\$590.00	\$560.00	\$620.00	\$558.00	\$608.00
BC-3l	36" Wide x 18" Tall	\$868.00	\$933.00	\$886.00	\$946.00	\$851.00	\$901.00
BC-3m	36" Wide x 24" Tall	\$960.00	\$1,025.00	\$973.00	\$1,033.00	\$929.00	\$979.00
BC-3n	36" Wide x 30" Tall	\$1,293.00	\$1,358.00	\$1,240.00	\$1,350.00	\$1,215.00	\$1,301.00
BC-3o	36" wide x 36" Tall	\$1,400.00	\$1,465.00	\$1,391.00	\$1,451.00	\$1,305.00	\$1,355.00
BC-3p	42" Wide x 12" Tall	\$639.00	\$704.00	\$668.00	\$728.00	\$655.00	\$705.00
BC-3q	42" Wide x 18" Tall	\$1,042.00	\$1,107.00	\$1,051.00	\$1,111.00	\$999.00	\$1,049.00
BC-3r	42" Wide x 24" Tall	\$1,148.00	\$1,213.00	\$1,152.00	\$1,212.00	\$1,090.00	\$1,140.00
BC-3s	42" Wide x 30" Tall	\$1,551.00	\$1,616.00	\$1,535.00	\$1,595.00	\$1,435.00	\$1,485.00
BC-3t	42" wide x 36" Tall	\$1,657.00	\$1,722.00	\$1,635.00	\$1,695.00	\$1,525.00	\$1,575.00
BC-3u	48" Wide x 12" Tall	\$671.00	\$736.00	\$699.00	\$759.00	\$683.00	\$733.00
BC-3v	48" Wide x 18" Tall	\$1,080.00	\$1,146.00	\$1,088.00	\$1,148.00	\$1,033.00	\$1,083.00
BC-3w	48" Wide x 24" Tall	\$1,192.00	\$1,257.00	\$1,194.00	\$1,254.00	\$1,128.00	\$1,178.00
BC-3x	48" Wide x 30" Tall	\$1,601.00	\$1,666.00	\$1,582.00	\$1,642.00	\$1,477.00	\$1,527.00
BC-3y	48" wide x 36" Tall	\$1,713.00	\$1,778.00	\$1,689.00	\$1,749.00	\$1,574.00	\$1,624.00

Catch Basins Must Be Cleaned Prior To Installation Installation is Based Upon Prevailing Wage Rates

Catchbasin Insert, Full Capture Device

BC-2 Curb Inlet Basket (Standard, HC Round and Continues)



<p>Company Contact: Bio Clean Environmental Services, Inc., Oceanside, CA Sales contacts: Greg Kent, (760) 433-7640 or Kirk Vallejo, (760) 681-9583 gkent@biocleanenvironmental.net kvallejo@biocleanenvironmental.net http://www.biocleanenvironmental.com</p>	<p>Meets San Francisco Bay Water Board full capture specifications</p>
<p>Storage capacity: range of sizes</p>	<p>Replacement Parts: Available</p>
<p>Vendor's maintenance estimate: Clean filter when over 40% full (May 1 - Sept 30); replace hydrocarbon boom at least 2 times per year</p>	<p>Warranty: 5 yrs</p>
<p>Material: Marine-grade fiberglass main body, stainless steel screen</p>	<p>Delivery Time: 50 or fewer 4 weeks; 50-100 6 weeks; 100-250 10 weeks; call for more than 250</p>
<p>Pricing: See over. Have uninstalled price. Traffic control not included in pricing</p>	

Comments from reference checks

Device effectiveness in capturing trash

Reference is positive. Prefers the round design for ease of maintenance and overall quality.

Maintenance issues/experience

Maintenance likes these. Uses a vactor truck to clean

Other:

Good customer service, on-time delivery, oil and grease absorbent filter

Curb Inlet Basket

Prices for Standard Curb Inlet Basket with "Easy Maintenance Shelf System"

Evaluated the easiest to clean by the City & County of Honolulu*
All Prices Include Installation

Size Range	Price per System	Price per System - Vendor Measured	Discounted Price - 25 to 100	Discounted Price - Vendor Measured - 25 to 100	Discounted Price - 101 and Over	Discounted Price - Vendor Measured - 101 and Over
2' - 4'	\$1,025.00	\$1,060.00	\$985.00	\$1,025.00	\$948.00	\$985.00
4'1" - 5'	\$1,085.00	\$1,125.00	\$1,045.00	\$1,085.00	\$1,006.00	\$1,045.00
5'1" - 7'	\$1,175.00	\$1,215.00	\$1,130.00	\$1,175.00	\$1,088.00	\$1,130.00
7'1" - 9'	\$1,280.00	\$1,330.00	\$1,235.00	\$1,280.00	\$1,190.00	\$1,235.00
9'1" - 11'	\$1,410.00	\$1,825.00	\$1,365.00	\$1,410.00	\$1,315.00	\$1,365.00
11'1" - 14'	\$1,515.00	\$1,565.00	\$1,460.00	\$1,515.00	\$1,407.00	\$1,460.00
14'1" - 18'	\$1,770.00	\$1,830.00	\$1,705.00	\$1,770.00	\$1,643.00	\$1,705.00
18'1" - 22'	\$1,950.00	\$2,020.00	\$1,880.00	\$1,950.00	\$1,812.00	\$1,880.00

Prices for High Capacity Round Curb Inlet Basket with "Easy Maintenance Shelf System"

All Prices Include Installation

Size Range	Price per System	Price per System - Vendor Measured	Discounted Price - 25 to 100	Discounted Price - Vendor Measured - 25 to 100	Discounted Price - 101 and Over	Discounted Price - Vendor Measured - 101 and Over
2' - 4'	\$1,170.00	\$1,210.00	\$1,125.00	\$1,170.00	\$1,083.00	\$1,125.00
4'1" - 5'	\$1,280.00	\$1,295.00	\$1,205.00	\$1,280.00	\$1,161.00	\$1,205.00
5'1" - 7'	\$1,365.00	\$1,415.00	\$1,315.00	\$1,365.00	\$1,267.00	\$1,315.00
7'1" - 9'	\$1,420.00	\$1,470.00	\$1,370.00	\$1,420.00	\$1,320.00	\$1,370.00
9'1" - 11'	\$1,535.00	\$1,590.00	\$1,480.00	\$1,535.00	\$1,426.00	\$1,480.00
11'1" - 14'	\$1,625.00	\$1,685.00	\$1,570.00	\$1,625.00	\$1,514.00	\$1,570.00
14'1" - 18'	\$1,730.00	\$1,900.00	\$1,770.00	\$1,730.00	\$1,707.00	\$1,770.00
18'1" - 22'	\$2,015.00	\$2,085.00	\$1,945.00	\$2,015.00	\$1,875.00	\$1,945.00

* Please reference "The Efficiency of Storm Drain Filters in Removing Pollutants from Urban Road Runoff". Prepared by Eric Heinen DeCarlo, PhD. & Robert J. Morenweck. Department of Oceanography, 1000 Pope Road, University of Hawaii, Honolulu, Hawaii 96822.

All of the Above System Prices Include "Easy Maintenance Shelf System"

Prices for Continues Curb Inlet Basket Without Easy Maintenance Shelf System

All Prices are per Basket Including Installation

Size Range	Price per Basket Installed	Price per Basket Installed - Vendor Measured	Discounted Price - 50 to 200 Baskets	Discounted Price - Vendor Measured - 50 to 200 Baskets	Discounted Price - 201 Baskets and Over	Discounted Price - Vendor Measured - 201 Baskets and Over
2' Basket	\$460.00	\$480.00	\$425.00	\$441.00	\$409.00	\$425.00
3' Basket	\$590.00	\$610.00	\$545.00	\$567.00	\$523.00	\$545.00
4' Basket	\$680.00	\$705.00	\$632.00	\$659.00	\$606.00	\$632.00

The Continues Baskets do not Include Shelf System

5 Year Warranty



Southern California
 2972 San Lus Rey Rd.
 Oceanside, CA 92058
 Phone 760-433-7640

Northern California
 690 Sunlow St.
 San Jose, CA 95126
 Phone 760-579-1584

The preceding information is confidential. It is not intended for transmission to, or receipt by, any unauthorized persons. If you have received this message in error, please (i) do not read it, (ii) reply to the sender that you received the fax and following information in error, and (iii) erase or destroy the message. Information contained in the preceding pages is solely for the recipient addressed in this cover letter. This fax (including all following pages) contains confidential information intended for the specific individual named above and the firm that person represents. This information has been provided in privacy and is protected by law. If you are not the intended recipient, you should delete this message. Any disclosure, copying, or distribution of any information, especially pricing, is strictly prohibited. Any distribution of this information is illegal unless approved by Bio Clean Environmental Services, Inc.

BC-2

Prices for Standard Curb Inlet Basket with "Easy Maintenance Shelf System"

All Prices Include Installation

Device ID	Size Range	Price per System	Price per System - Vendor Measured	Discounted Price - 25 to 100	Discounted Price - Vendor Measured - 25 to 100	Discounted Price - 101 and Over	Discounted Price - Vendor Measured - 101 and Over
BC-2a	2' - 4'	\$1,025.00	\$1,060.00	\$985.00	\$1,025.00	\$948.00	\$985.00
BC-2b	4'1" - 5'	\$1,085.00	\$1,125.00	\$1,045.00	\$1,085.00	\$1,006.00	\$1,045.00
BC-2c	5'1" - 7'	\$1,175.00	\$1,215.00	\$1,130.00	\$1,175.00	\$1,088.00	\$1,130.00
BC-2d	7'1" - 9'	\$1,280.00	\$1,330.00	\$1,235.00	\$1,280.00	\$1,190.00	\$1,235.00
BC-2e	9'1" - 11'	\$1,410.00	\$1,465.00	\$1,365.00	\$1,410.00	\$1,315.00	\$1,365.00
BC-2f	11'1" - 14'	\$1,515.00	\$1,565.00	\$1,460.00	\$1,515.00	\$1,407.00	\$1,460.00
BC-2g	14'1" - 18'	\$1,770.00	\$1,830.00	\$1,705.00	\$1,770.00	\$1,643.00	\$1,705.00
BC-2h	18'1" - 22'	\$1,950.00	\$2,020.00	\$1,880.00	\$1,950.00	\$1,812.00	\$1,880.00

Prices for High Capacity Round Curb Inlet Basket with "Easy Maintenance Shelf System"

All Prices Include Installation

Device ID	Size Range	Price per System	Price per System - Vendor Measured	Discounted Price - 25 to 100	Discounted Price - Vendor Measured - 25 to 100	Discounted Price - 101 and Over	Discounted Price - Vendor Measured - 101 and Over
BC-2ar	2' - 4'	\$1,170.00	\$1,210.00	\$1,125.00	\$1,170.00	\$1,083.00	\$1,125.00
BC-2br	4'1" - 5'	\$1,280.00	\$1,295.00	\$1,205.00	\$1,280.00	\$1,161.00	\$1,205.00
BC-2cr	5'1" - 7'	\$1,365.00	\$1,415.00	\$1,315.00	\$1,365.00	\$1,267.00	\$1,315.00
BC-2dr	7'1" - 9'	\$1,420.00	\$1,470.00	\$1,370.00	\$1,420.00	\$1,320.00	\$1,370.00
BC-2er	9'1" - 11'	\$1,535.00	\$1,590.00	\$1,480.00	\$1,535.00	\$1,426.00	\$1,480.00
BC-2fr	11'1" - 14'	\$1,625.00	\$1,685.00	\$1,570.00	\$1,625.00	\$1,514.00	\$1,570.00
BC-2gr	14'1" - 18'	\$1,730.00	\$1,900.00	\$1,770.00	\$1,730.00	\$1,707.00	\$1,770.00
BC-2hr	18'1" - 22'	\$2,015.00	\$2,085.00	\$1,945.00	\$2,015.00	\$1,875.00	\$1,945.00

All of the Above System Prices Include "Easy Maintenance Shelf System"

Prices for Continues Curb Inlet Basket Without Easy Maintenance Shelf System

All Prices are per Basket Including Installation

Device ID	Size Range	Price per Basket Installed	Price per Basket Installed - Vendor Measured	Discounted Price - 50 to 200 Baskets	Discounted Price - Vendor Measured - 50 to 200 Baskets	Discounted Price - 201 Baskets and Over	Discounted Price - Vendor Measured - 201 Baskets and Over
BC-2i	2' Basket	\$460.00	\$480.00	\$425.00	\$441.00	\$409.00	\$425.00
BC-2j	3' Basket	\$590.00	\$610.00	\$545.00	\$567.00	\$523.00	\$545.00
BC-2k	4' Basket	\$680.00	\$705.00	\$632.00	\$659.00	\$606.00	\$632.00

Note: The Continues Baskets do not Include Shelf System

Catchbasin Insert, Full Capture Device

BC-1 Grate Inlet Skimmer Box (square design) Catchbasin filter



<p>Company Contact: Bio Clean Environmental Services, Inc., Oceanside, CA Sales contacts: Greg Kent, (760) 433-7640 or Kirk Vallejo, (760) 681-9583 gkent@biocleanenvironmental.net kvallejo@biocleanenvironmental.net http://www.biocleanenvironmental.com</p>	<p>Meets San Francisco Bay Water Board full capture specifications</p>
<p>Storage capacity: range of sizes</p>	<p>Replacement Parts: Available</p>
<p>Vendor's maintenance estimate: Clean filter when over 40% full (May 1 - Sept 30); replace hydrocarbon boom at least 2 times per year</p>	<p>Warranty: 5 yrs</p>
<p>Material: Marine-grade fiberglass main body, stainless steel screen</p>	<p>Delivery Time: 50 or fewer 4 weeks; 50-100 6 weeks; 100-250 10 weeks; call for more than 250</p>
<p>Pricing: See over. Have uninstalled price. Traffic control not included in pricing</p>	

Comments from reference checks

Device effectiveness in capturing trash

Reference is positive. Prefers the round design for ease of maintenance and overall quality.

Maintenance issues/experience

Maintenance likes these. Uses a vactor truck to clean

Other:

Good customer service, on-time delivery, oil and grease absorbent filter

GRATE INLET SKIMMER BOX

Prices for Standard Grate Inlet Skimmer Box

Inlet Baskets for Grated Type Catch Basins

All Prices Include Installation Under Grate

Size Range	Price per System	Price per System - Vendor Measured	Discounted Price - 40 to 100	Discounted Price - Vendor Measured - 40 to 100	Discounted Price - 101 and Over	Discounted Price - Vendor Measured - 101 and Over
Up to 12" x 12"	\$662.00	\$688.00	\$635.00	\$662.00	\$609.00	\$630.00
To 18" x 18"	\$777.00	\$808.00	\$725.00	\$757.00	\$694.00	\$725.00
To 24" x 24"	\$813.00	\$848.00	\$780.00	\$793.00	\$727.00	\$760.00
To 24" x 36"	\$866.00	\$901.00	\$810.00	\$846.00	\$725.00	\$810.00
To 36" x 36"	\$938.00	\$976.00	\$880.00	\$918.00	\$842.00	\$880.00
To 40" x 40"	\$1,043.00	\$1,086.00	\$980.00	\$1,023.00	\$937.00	\$980.00
To 48" x 48"	\$1,148.00	\$1,205.00	\$1,100.00	\$1,128.00	\$1,032.00	\$1,100.00
Filter Basket is Manufactured to Fit Catch Basin Dimensions at No Additional Cost						
Depths Can Vary from 12" to 24"						

Prices for "Tray" Grate Inlet Skimmer Box

Inlet Baskets for Shallow Grated Type Catch Basins and Have No Deflector Shield

All Prices Include Installation Under Grate

Size Range	Price per System	Price per System - Vendor Measured	Discounted Price - 40 to 100	Discounted Price - Vendor Measured - 40 to 100	Discounted Price - 101 and Over	Discounted Price - Vendor Measured - 101 and Over
Up to 12" x 12"	\$600.00	\$624.00	\$575.00	\$600.00	\$551.00	\$575.00
To 18" x 18"	\$704.00	\$733.00	\$665.00	\$694.00	\$637.00	\$665.00
To 24" x 24"	\$741.00	\$771.00	\$710.00	\$741.00	\$680.00	\$710.00
To 24" x 36"	\$813.00	\$846.00	\$760.00	\$793.00	\$727.00	\$760.00
To 36" x 36"	\$866.00	\$901.00	\$810.00	\$846.00	\$775.00	\$810.00
To 40" x 40"	\$960.00	\$1,000.00	\$920.00	\$960.00	\$880.00	\$920.00
To 48" x 48"	\$1,065.00	\$1,110.00	\$1,020.00	\$1,065.00	\$975.00	\$1,020.00
Filter Basket is Manufactured to Fit Catch Basin Dimensions at No Additional Cost						
Depths Can Vary from 8" to 11"						

Undermount Installation is an Additional 5% Cost per Basket
Steel Flanges are an Additional \$50.00 Cost per Basket
Catch Basin Must be Cleaned Prior to Installation

5 Year Warranty



Southern California
 2972 San Lus Rey Rd.
 Oceanside, CA 92058
 Phone 760-433-7640

Northern California
 690 Sunlow St.
 San Jose, CA 95126
 Phone 760-579-1584

The preceding information is confidential. It is not intended for transmission to, or receipt by, any unauthorized persons. If you have received this message in error, please (i) do not read it, (ii) reply to the sender that you received the fax and following information in error, and (iii) erase or destroy the message. Information contained in the preceding pages is solely for the recipient addressed in this cover letter. This fax (including all following pages) contains confidential information intended for the specific individual named above and the firm that person represents. This information has been provided in privacy and is protected by law. If you are not the intended recipient, you should delete this message. Any disclosure, copying, or distribution of any information, especially pricing, is strictly prohibited. Any distribution of this information is illegal unless approved by Bio Clean Environmental Services, Inc.

BC-1**Standard Grate Inlet Skimmer Box
Inlet Baskets for Grated Type Catch Basins**

All Prices Include Installation Under Grate

Depths Can Vary from 12" to 24"

Project Device ID	Size Range	Price per System	Price per System Vendor Measured	Discounted Price 40 to 100	Discounted Price - Vendor Measured 40 to 100	Discounted Price - 101 and Over	Discounted Price - Vendor Measured 101 and Over
BC-1a	Up to 12" x 12"	\$662.00	\$688.00	\$635.00	\$662.00	\$609.00	\$630.00
BC-1b	To 18" x 18"	\$777.00	\$808.00	\$725.00	\$757.00	\$694.00	\$725.00
BC-1c	To 24" x 24"	\$813.00	\$848.00	\$780.00	\$793.00	\$727.00	\$760.00
BC-1d	To 24" x 36"	\$866.00	\$901.00	\$810.00	\$846.00	\$725.00	\$810.00
BC-1e	To 36" x 36"	\$938.00	\$976.00	\$880.00	\$918.00	\$842.00	\$880.00
BC-1f	To 40" x 40"	\$1,043.00	\$1,086.00	\$980.00	\$1,023.00	\$937.00	\$980.00
BC-1g	To 48" x 48"	\$1,148.00	\$1,205.00	\$1,100.00	\$1,128.00	\$1,032.00	\$1,100.00

**"Tray" Grate Inlet Skimmer Box
Inlet Baskets for Shallow Grated Type Catch Basins
and Have No Deflector Shield**

All Prices Include Installation Under Grate

Depths Can Vary from 8" to 11"

Project Device ID	Size Range	Price per System	Price per System Vendor Measured	Discounted Price 40 to 100	Discounted Price - Vendor Measured 40 to 100	Discounted Price - 101 and Over	Discounted Price - Vendor Measured 101 and Over
BC-1Ta	Up to 12" x 12"	\$600.00	\$624.00	\$575.00	\$600.00	\$551.00	\$575.00
BC-1Tb	To 18" x 18"	\$704.00	\$733.00	\$665.00	\$694.00	\$637.00	\$665.00
BC-1Tc	To 24" x 24"	\$741.00	\$771.00	\$710.00	\$741.00	\$680.00	\$710.00
BC-1Td	To 24" x 36"	\$813.00	\$846.00	\$760.00	\$793.00	\$727.00	\$760.00
BC-1Te	To 36" x 36"	\$866.00	\$901.00	\$810.00	\$846.00	\$775.00	\$810.00
BC-1Tf	To 40" x 40"	\$960.00	\$1,000.00	\$920.00	\$960.00	\$880.00	\$920.00
BC-1Tg	To 48" x 48"	\$1,065.00	\$1,110.00	\$1,020.00	\$1,065.00	\$975.00	\$1,020.00

Undermount Installation is an Additional 5% Cost per Basket

Steel Flanges are an Additional \$50.00 Cost per Basket

Catch Basin Must be Cleaned Prior to Installation

Catchbasin Insert, Full Capture Device

AS-1,AS-2 Stormtek ST3 and ST3G

Catchbasin Connector Pipe Screen (CPS), removable



ST3G



ST3

<p>Company Contact: Advanced Solutions, Corona, CA Sales contact: Octavio Lugo, 714-457-3283 advancedsolutions@gmail.com http://www.advancedsolutionsla.com</p>	<p>Certified full capture by LA Regional Water Board Meets San Francisco Bay Water Board full capture specifications</p>
<p>Storage capacity: 90% of the volume of the catchbasin</p>	<p>Replacement Parts: Available</p>
<p>Vendor's maintenance recommendation: Inspect before and after major rain event</p>	<p>Warranty: 2 yrs</p>
<p>Material: S-304 stainless steel</p>	<p>Delivery Time: For 100 Units, approx. 3-4 Weeks</p>

Comments from reference checks

Device effectiveness in capturing trash

Overflow was not adequate, device clogged quickly in an intense storm in Southern California

Maintenance issues/experience

Couldn't pull out when very full, suggested a handle and larger mounting pins to vendor

Other:

Note that pricing is the same for both models

Reference reports great customer service

Installed in Oakland, San Jose, and Sunnyvale

AS-1 & AS-2

ST3 or ST3-G

StormTek device pricing

*Municipal staff installation reduces cost by \$190 per unit

ST3

Device ID	Number of Units	Price Per Unit
AS-1	1 - 99 units	\$1,429
AS-1	100 - 250 units	\$ 1,399
AS-1	251 - 500 units	\$ 1,299
AS-1	501 - 750 units	\$ 1,199
AS-1	750 +	\$ 1,099

ST3-G

Device ID	Number of Units	Price Per Unit
AS-2	1 - 99 units	\$1,429
AS-2	100 - 250 units	\$ 1,399
AS-2	251 - 500 units	\$ 1,299
AS-2	501 - 750 units	\$ 1,199
AS-2	750 +	\$ 1,099

WCS-2 ARS- Automatic Retractable Scree

Automatic retractable screen for curb inlets

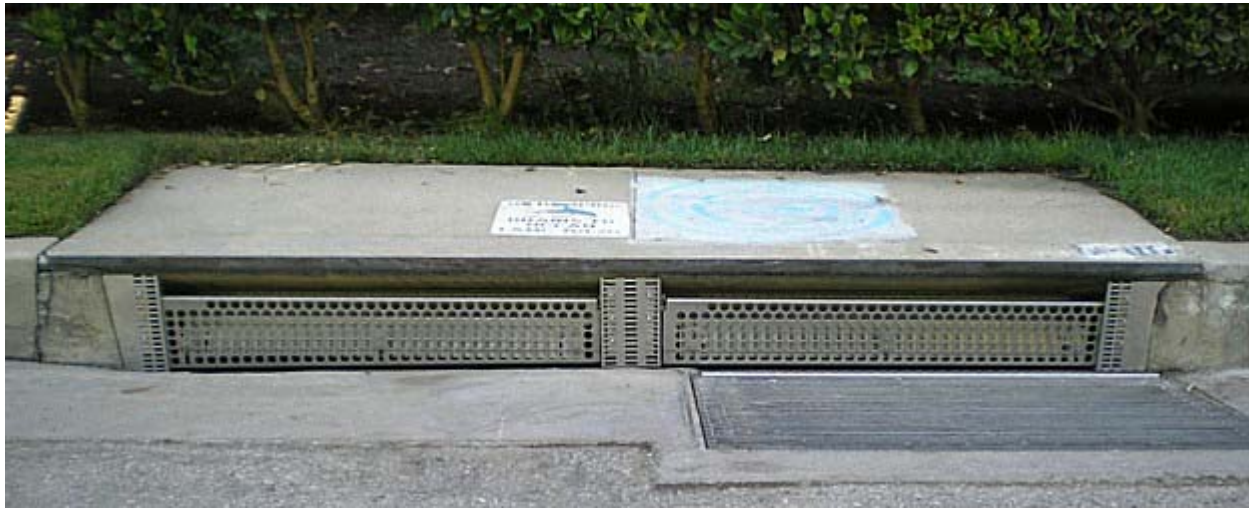

<p>Company Contact: West Coast Storm, Inc., San Bernardino, CA Sales contact: Brian Martello, (909) 717-8855 bmartello@wcstorm.net http://westcoaststorm.com</p>	<p>For use in series with full capture device</p>
<p>Storage capacity: n/a</p>	<p>Replacement Parts: Available</p>
<p>Vendor's maintenance estimate: "Built-up debris and foreign object debris can hinder the unit's operation. Remove any visible debris that may be on, in front of and nearby the unit."</p>	<p>Warranty: 10 years</p>
<p>Material: stainless steel</p>	<p>Delivery Time: estimated 3 days time per one day quantity of installs</p>
<p>Pricing: See over</p>	

- Q. Price including price breaks or discounts for quantity orders. **Price must include installation.** If you offer an uninstalled price (i.e., if municipal staff may successfully install the device), also include pricing for delivery only. Prices shall remain in effect for two years from contract execution or amendment. (Attach extra sheets or a detailed price list or spreadsheet as appropriate.)

WEST COAST STORM CONNECTOR PIPE SCREEN

Pricing, including installation, is as follows:

Per unit cost for CPS Devices fitting a connector pipe of 6 inches to 48 inches.

For orders of 25 CPS devices or more:

\$ 428.18 each CPS device

Per unit cost for CPS Devices fitting a connector pipe of 6 inches to 48 inches.

For orders of 24 CPS devices or less:

\$ 575.00 each CPS device

Pricing, NOT including installation, is as follows:

Per unit cost for CPS Devices fitting a connector pipe of 6 inches to 48 inches.

\$ 370.00 each CPS device

Pricing includes parts for installation of unit ordered.

Pricing does not include ACCESS database or drain mapping provisions as stated above.

Warranty is void if the device is not installed by a WCS Certified Installer. For Single Orders of 200 or more CPS Devices, WCS will train and certify qualified installers.

WEST COAST STORM SCREEN (AUTOMATIC RETRACTABLE SCREEN)

Pricing, including installation, is as follows:

Per unit cost for ARS Devices up to 48 inches in length.

\$ 327.00 each ARS device

Pricing, NOT including installation, is as follows:

Per unit cost for ARS Devices up to 48 inches in length.

\$ 270.00 each ARS device

Pricing includes parts for installation of unit ordered.

Pricing does not include ACCESS database or drain mapping provisions as stated above.

Warranty is void if the device is not installed by a WCS Certified Installer. For Single Orders of 200 or more ARS Devices, WCS will train and certify qualified installers.

- R. Options and/or exclusions

None to report.

West Coast Storm

WCS-1

Connector Pipe Screen

Including Installation

Device ID	Outlet Pipe Dimensions	Quantity	Price Stainless Baskets (C3) Per Unit
WCS-1	6" – 48"	1-24	\$ 575.00
WCS-1	6" – 48"	24 or more	\$ 428.18

Not Including Installation

Device ID	Outlet Pipe Dimensions	Quantity	Price Stainless Baskets (C3) Per Unit
WCS-1	6" – 48"	1 or more	\$370.00

Pricing, **NOT including installation**, is as follows:

Warranty is void if the device is not installed by a WCS Certified Installer. For single orders of 200 or more CPS devices, WCS will train and certify qualified installers. Price includes parts for installation of unit. Price does not include ACCESS database or drain mapping provisions as stated in vendor contract.

WCS-2

ARS- Automatic Retractable Screen

Including Installation

Device ID	Length	Quantity	Price Per Unit
WCS-2	Up to 48"	1 or more	\$327.00

Not Including Installation

Device ID	Length	Quantity	Price Per Unit
WCS-2	Up to 48"	1 or more	\$270.00

Pricing, **NOT including installation**, is as follows:

Warranty is void if the device is not installed by a WCS Certified Installer. For single orders of 200 or more ARS devices, WCS will train and certify qualified installers. Price includes parts for installation of unit. Price does not include ACCESS database or drain mapping provisions as stated in vendor contract

USW-2 Clean Screen III
Automatic Retractable (inlet) Screen; ARS



<p>Company Contact: United Stormwater, Inc., City of Industry, CA Sales contact: Chris Anguiano, 626-290-5372 christian@unitedpumping.com http://www.unitedstormwater.com/</p>	<p>For use in series with full capture device</p>
<p>Storage capacity: n/a</p>	<p>Replacement Parts: Available</p>
<p>Vendor's maintenance estimate: no maintenance on the unit itself</p>	<p>Warranty: 3 yrs</p>
<p>Material: 304 stainless steel</p>	<p>Delivery Time: Within 90 days</p>
<p>Pricing: See over.</p>	

United Stormwater Full-Capture Devices

USW-1 Connector Pipe Screen

***Minimum order is 5 units**

Device ID	Quantity	Price
USW-1	5 to 9	\$515.00
USW-1	10 to 49	\$475.00
USW-1	50 to 99	\$425.00
USW-1	100 or more	\$409.00

Prices exclude cleaning of Catch Basin, disposal of material. Price subject to increases in cost and material

United Stormwater Partial Capture Devices

USW-2 Clean Screen III

***Minimum order is 5 units**

Device ID	Quantity	Price
USW-2	5 to 9	\$636.00
USW-2	10 to 49	\$560.00
USW-2	50 to 99	\$515.00
USW-2	100 or more	\$490.00

Prices exclude cleaning of Catch Basin, disposal of material. Price subject to increases in cost and materials

USW-3 Manual Retractable Screen (Curb Inlet Screen)

Device ID	Quantity	Price
USW-3	1 to 9	\$450.00
USW-3	10 to 49	\$425.00
USW-3	50 to 99	\$400.00
USW-3	100 or more	\$375.00

USW-4 - DrainPac (Curb Inlet Design)

***Prices do not include installation**

Device ID	Size	Price
USW-4a	41"x12"x12"	\$375.00
USW-4b	48"x12"x12"	\$425.00
USW-4c	60"x12"x12"	\$475.00
USW-4d	82"x12"x12"	\$525.00

USW-5 - DrainPac (Drop Inlet Design)

***Prices do not include installation**

Device ID	Size	Price
USW-5a	12"x12"	\$275.00
USW-5b	18"x18"	\$325.00
USW-5c	24"x24"	\$385.00
USW-5d	36"x36"	\$450.00
USW-5e	48"x48"	\$650.00
USW-5f	25"x38"	\$425.00

KS-4 Trash and Debris Guard
Fixed Inlet screen

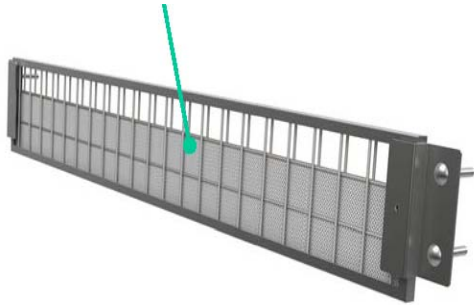

Face-Mount

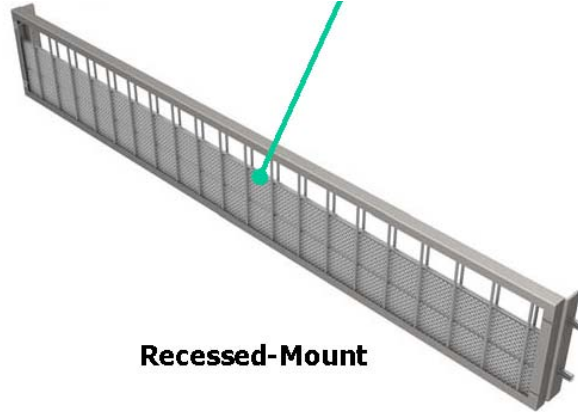

Recessed-Mount

<p>Company Contact: KriStar Enterprises, Inc., Santa Rosa, CA Sales contact: Sue Lillo, 800-579-8819 slillo@kristar.com http://www.kristar.com</p>	<p>For use in series with full capture device</p>
<p>Storage capacity: n/a</p>	<p>Replacement Parts: Available</p>
<p>Vendor's maintenance estimate: frequent dry season street sweeping, wet season removal, see Kristar maintenance guidelines in proposal</p>	<p>Warranty: 5 years</p>
<p>Material: 304 stainless steel, woven polypropylene, optional fossil rock filter</p>	<p>Delivery Time: 1 week standard to 3 weeks for custom</p>
<p>Pricing: See over.</p>	

- (5) Optional Items
 - (a) Fossil Rock Pouches @ \$15.00 per pouch
 - (b) Stainless Steel Trash and Debris Guards @ \$375.00 per each

- (4) Prices do not include any applicable sales taxes
- (5) There are no quantity purchase discounts available for this item

KS-4

Trash and Debris Guards (stainless steel)

Device ID	Unit Price
KS-4	\$ 375.00

Large Devices

KS-5HF

Cleans All Gross Pollutant Trap

Device ID	Unit Price
KS-5HF	Pricing for this product is estimated to range from \$60,000 to \$220,000 per installation. Each location will need to be individually evaluated to determine final pricing based upon the site specific conditions.

KS-6HF

Downstream Defender

Device ID	Unit Price
KS-6HF4	\$ 12,900.00
KS-6HF6	\$ 22,500.00
KS-6HF8	\$37,500.00
KS-6HF10	\$65,000.00

NOTES:

- (1) Actual dimensions will be field verified by KriStar prior to fabrication and installation
- (2) Products manufactured in accordance with Buy American contract provisions
- (3) Prices include precast concrete components, bolted, gasketed lids, factory-installed internal components and delivery to jobsite
- (4) Purchaser is responsible for offloading and setting of structures
- (5) Prices do not include diversion structures
- (6) Prices do not include any applicable sales taxes
- (7) There is no purchase quantity discount available for this product

For Use in Series With Full Capture Device

GFI-2 ARS Automatic retractable screen for curb inlets



<p>Company Contact: Gentile Family Industries (Waterway Solutions) Wilmington, CA Sales contact: Gail Brice, 562-592-5989 gail.brice@waterwaysolution.com http://gfindustries.net</p>	<p>For use in series with full capture device</p>
<p>Storage capacity: n/a</p>	<p>Replacement Parts: Available</p>
<p>Vendor's maintenance estimate:</p>	<p>Warranty: 5 yrs</p>
<p>Material: Marine-grade 316 stainless steel</p>	<p>Delivery Time: "45 days from initial order. Once inventory is in place, maximum of two weeks to installation."</p>
<p>Pricing: See over.</p>	

Gentile Family Industries – (Waterway Solutions)

SMALL CATCH BASINS < 36" DEEP

WAVY Grate Trash Catcher – Vendor Model GFI-1-GS (Grated Inlet)

Device ID	Number of Devices	Price per Unit (Includes Installation)
GFI-1GS	10-49	\$399.00
GFI-1GS	50-99	\$375.00
GFI-1GS	100-499	\$365.00
GFI-1GS	500-999	\$349.00
GFI-1GS	1000-2499	\$330.00
GFI-1GS	2499-5000+	\$299.00

Note: Orders of less than 10 units will be charged a minimum of \$4800.00

WAVY Grate Trash Catcher – Vendor Model GFI-1-CS (Curb Inlet)

Device ID	Number of Devices	Price per Unit (Includes Installation)
GFI-1CS	10-49	\$399.00
GFI-1CS	50-99	\$375.00
GFI-1CS	100-499	\$365.00
GFI-1CS	500-999	\$349.00
GFI-1CS	1000-2499	\$330.00
GFI-1CS	2499-5000+	\$299.00

Note: Orders of less than 10 units will be charged a minimum of \$4800.00

MEDIUM CATCH BASINS (36" – 60" Deep)

WAVY Grate Trash Catcher – Vendor Model GFI-1-GM (Grated Inlet)

Device ID	Number of Devices	Price per Unit (Includes Installation)
GFI-1GM	10-49	\$440.00
GFI-1GM	50-99	\$425.00
GFI-1GM	100-499	\$415.00
GFI-1GM	500-999	\$410.00
GFI-1GM	1000-2499+	\$375.00

Note: Orders of less than 10 units will be charged a minimum of \$4800.00

WAVY Grate Trash Catcher – Vendor Model GFI-1-CM (Curb Inlet)

Device ID	Number of Devices	Price per Unit (Includes Installation)
GFI-1CM	10-49	\$440.00
GFI-1CM	50-99	\$425.00
GFI-1CM	100-499	\$415.00
GFI-1CM	500-999	\$410.00
GFI-1CM	1000-2499+	\$375.00

Note: Orders of less than 10 units will be charged a minimum of \$4800.00

LARGE CATCH BASINS (61" – 96" Deep)

WAVY Grate Trash Catcher – Vendor Model GFI-1-GL (Grated Inlet)

Device ID	Number of Devices	Price per Unit (Includes Installation)
GFI-1GL	10-49	\$485.00
GFI-1GL	50-99	\$475.00
GFI-1GL	100-499	\$460.00
GFI-1GL	500-999	\$455.00
GFI-1GL	1000-2499	\$445.00
GFI-1GL	2499-5000+	\$425.00

Note: Orders of less than 10 units will be charged a minimum of \$4800.00

WAVY Grate Trash Catcher – Vendor Model GFI-1-CL (Curb Inlet)

Device ID	Number of Devices	Price per Unit (Includes Installation)
GFI-1CL	10-49	\$485.00
GFI-1CL	50-99	\$475.00
GFI-1CL	100-499	\$460.00
GFI-1CL	500-999	\$455.00
GFI-1CL	1000-2499	\$445.00
GFI-1CL	2499-5000+	\$425.00

Note: Orders of less than 10 units will be charged a minimum of \$4800.00

Curb Inlet Screens

ARS- Automatic Retractable Screen – Vendor Model GFI TS (1 thru 6)

Device ID	Curb Opening Length	Vendor Model Number	Price per Unit (Includes Installation)
GFI-2TS1	<5 feet	GFI-2-TS-1	\$360.00
GFI-2TS2	5-10 feet	GFI-2-TS-2	\$425.00
GFI-2TS3	10-15 feet	GFI-2-TS-3	\$905.00
GFI-2TS4	15-20 feet	GFI-2-TS-4	\$1235.00
GFI-2TS5	20-25 feet	GFI-2-TS-5	\$1525.00
GFI-2TS6	25-30 feet	GFI-2-TS-6	\$2100.00

Note: Minimum order \$3600.00. 10% Discount for order of 100+ ARS devices.

G2-3 FS 10 Fixed Screen

Fixed inlet screen

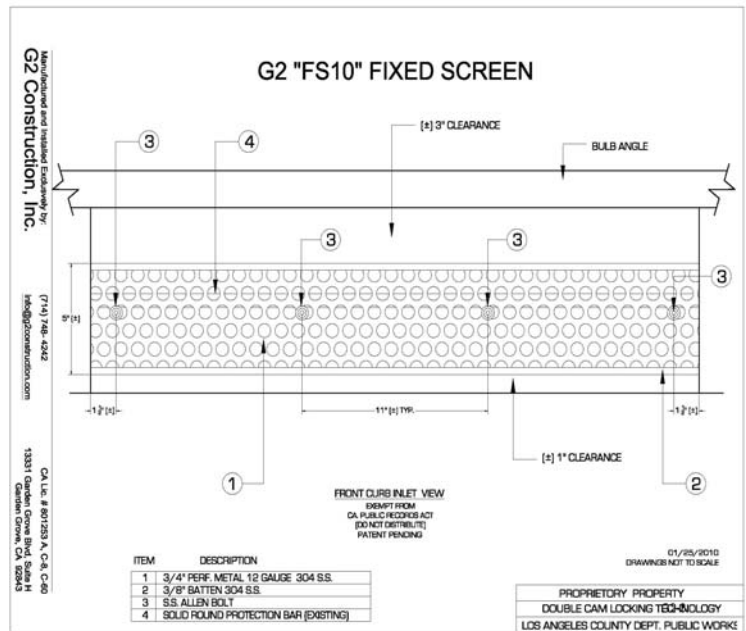

<p>Company Contact: G2 Construction, Inc., Garden Grove, CA Sales contact: John R. Alvarado, 714-448-8080 jalvarado@g2construction.com http://g2construction.com</p>	<p>For use in series with full capture device</p>
<p>Storage capacity: n/a</p>	<p>Replacement Parts: Available</p>
<p>Vendor's maintenance estimate: Device will require cleaning from the street level, which can be achieved by street sweeper truck or manually. Maximum cleaning time approx. 3 minutes</p>	<p>Warranty: 1 yr workmanship/5 yrs parts+materials</p>
<p>Material: Series 304 12-gauge stainless steel</p>	<p>Delivery Time: Within 90 days</p>
<p>Pricing: See over.</p>	

Comments from reference checks

Device effectiveness in capturing trash

The device did not cause flood issues and was able to contain the trash well (especially leaf debris).

Maintenance issues/experience

Installation was difficult in the beginning but after adjustments were made installation was straightforward. The reference experienced good service with the vendor.

SFBA G2 "FS10" Fixed Screen Stainless Steel 3/4" perforated

Pricing Scale

Catch Basin W= Length	Min. order Qty.	Price per unit
1). W= 3.5'	100 ea.	\$ 195.00
2). W= 7'	80 ea.	\$ 341.00
3). W=10'	70 ea.	\$ 452.00
4). W=14'	50 ea.	\$ 628.00
5). W=16'	40 ea.	\$ 815.00
6). W=21'	30 ea.	\$ 972.00
7). W=28	25 ea.	\$1,240.00
8). W=35	20 ea.	\$1,535.00

- Notes; Pricing does not include catch basin protection bar.
- Pricing does not include catch basin cleaning
- Pricing does not include permits or fees
- Pricing does include product and installation at prevailing wages.

This is a Stainless Steel 3/4" dia. perforated screen 12 gauge installed with dome head allen bolt and nut stainless steel hardware.

This device is installed with a 1" open area at flowline and a 2" - 3" open area at top of screen for by pass during high flow events. This product is intended to keep large debris objects from entering the storm drain system.

Pricing to remain in effect for 2 years from bid due date.

G2-2 “G2 - CAM LOCK” Automatic Retractable Screen

Device ID	Width	Minimum Order Quantity	Price per Unit
G2-2a	3.5'	25	\$450.00
G2-2b	7'	25	\$825.00
G2-2c	10'	25	\$825.00
G2-2d	14'	15	\$1,275.00
G2-2e	16'	15	\$1,375.00
G2-2f	21'	5	\$2,000.00
G2-2g	28'	5	\$2,500.00
G2-2h	35'	5	\$2,850.00

Note: Pricing does not include catch basin cleaning
Pricing does not include permits or fees
Pricing does include product and installation at prevailing wages
Pricing does include catch basin galvanized protection bar.

This device is installed with a ½” open area at flowline and a 2” open area along top for bypass during high flow events. This product is intended to keep large Debris objects from entering the storm drain during periods of non water events.

Our device is modeled after L.A. County designs and parameters.
New parameters or minimum device sizing will have to be determined by local agencies prior to installation.

Pricing to remain in effect for 2 years from original bid due date.

G2-3 FS10 (Fixed Curb Inlet Screen)

Device ID	Width	Minimum Order Quantity	Price per Unit
G2-3a	3.5'	100	\$195.00
G2-3b	7'	80	\$341.00
G2-3c	10'	70	\$452.00
G2-3d	14'	50	\$628.00
G2-3e	16'	40	\$815.00
G2-3f	21'	30	\$975.00
G2-3g	28'	25	\$1,240.00
G2-3h	35'	20	\$1,535.00

Note: Pricing does not include catch basin protection bar.
Pricing does not include catch basin cleaning
Pricing does not include permits or fees
Pricing does include product and installation at prevailing wages

This is a Stainless Steel ¾” diameter perforated screen 12 gauge installed with dome head allen bolt and nut stainless steel hardware

This device is installed with a 1” open area at flowline and a 2”-3” open area at top of screen for bypass during high flow events. This product is intended to keep large deris objects from entering the storm drain system.

Pricing to remain in effect for 2 years from bid due date.

G2-2 CamLock Debris Gate

Automatic retractable screen (pop-open inlet grate)



<p>Company Contact: G2 Construction, Inc., Garden Grove, CA Sales contact: John R. Alvarado, 714-448-8080 jalvarado@g2construction.com http://g2construction.com</p>	<p>For use in series with full capture device</p>
<p>Storage capacity: n/a</p>	<p>Replacement Parts: Available</p>
<p>Vendor's maintenance estimate: Device will require cleaning from the street level, which can be achieved by street sweeper truck or manually. Maximum cleaning time approx. 3 minutes</p>	<p>Warranty: 1 yr workmanship/5 yrs parts+materials</p>
<p>Material: Series 304 12-gauge stainless steel</p>	<p>Delivery Time: 10 working days from receipt of order to installation</p>
<p>Pricing: See over.</p>	

Comments from reference checks

Device effectiveness in capturing trash

The device did not cause flood issues and was able to contain the trash well (especially leaf debris).

Maintenance issues/experience

Installation was difficult in the beginning but after adjustments were made installation was straightforward. The reference experienced good service with the vendor.

SFBA G2 ARS "CAM LOCK" Debris Gates

Pricing Scale

	Catch Basin W= Length	Min. order Qty.	Price per unit
1).	W= 3.5'	200 ea.	\$ 380.00
2).	W= 7'	100 ea.	\$ 760.00
3).	W=10'	100 ea.	\$ 795.00
4).	W=14'	70 ea.	\$ 1,140.00
5).	W=16'	55 ea.	\$ 1,475.00
6).	W=21'	40 ea.	\$ 1,850.00
7).	W=28	35 ea.	\$ 2,175.00
8).	W=35	30 ea.	\$ 2,650.00

Notes; G2 seeking minimum orders of \$75,000.00 (combining sizes encouraged)

Discounts..... Orders exceeding \$350,000 apply 2.5% discount

Orders exceeding \$700,000 apply 5% discount

Discount orders apply to 1st. Year from bid due date only.

Pricing does include catch basin galvanized protection bar.

Pricing does not include catch basin cleaning

Pricing does not include permits or fees

Pricing does include product and installation at prevailing wages.

This device is installed with a 1/2" open area at flowline and a 2" open area at top of screen for by pass during high flow events. This product is intended to keep large debris objects from entering the storm drain system.

Above pricing (#1 through #8) to remain in effect for 2 years from bid due date.

G2-2 “G2 - CAM LOCK” Automatic Retractable Screen

Device ID	Width	Minimum Order Quantity	Price per Unit
G2-2a	3.5'	25	\$450.00
G2-2b	7'	25	\$825.00
G2-2c	10'	25	\$825.00
G2-2d	14'	15	\$1,275.00
G2-2e	16'	15	\$1,375.00
G2-2f	21'	5	\$2,000.00
G2-2g	28'	5	\$2,500.00
G2-2h	35'	5	\$2,850.00

Note: Pricing does not include catch basin cleaning
Pricing does not include permits or fees
Pricing does include product and installation at prevailing wages
Pricing does include catch basin galvanized protection bar.

This device is installed with a ½” open area at flowline and a 2” open area along top for bypass during high flow events. This product is intended to keep large Debris objects from entering the storm drain during periods of non water events.

Our device is modeled after L.A. County designs and parameters.
New parameters or minimum device sizing will have to be determined by local agencies prior to installation.

Pricing to remain in effect for 2 years from original bid due date.

G2-3 FS10 (Fixed Curb Inlet Screen)

Device ID	Width	Minimum Order Quantity	Price per Unit
G2-3a	3.5'	100	\$195.00
G2-3b	7'	80	\$341.00
G2-3c	10'	70	\$452.00
G2-3d	14'	50	\$628.00
G2-3e	16'	40	\$815.00
G2-3f	21'	30	\$975.00
G2-3g	28'	25	\$1,240.00
G2-3h	35'	20	\$1,535.00

Note: Pricing does not include catch basin protection bar.
Pricing does not include catch basin cleaning
Pricing does not include permits or fees
Pricing does include product and installation at prevailing wages

This is a Stainless Steel ¾” diameter perforated screen 12 gauge installed with dome head allen bolt and nut stainless steel hardware

This device is installed with a 1” open area at flowline and a 2”-3” open area at top of screen for bypass during high flow events. This product is intended to keep large deris objects from entering the storm drain system.

Pricing to remain in effect for 2 years from bid due date.

For Use in Series With Full Capture Device

ECI-2 Surfgate Pop open inlet grate



<p>Company Contact: Ecology Control Industries (American Stormwater), Torrance, CA Sales contact: Todd Waters, 310-354-9999 x284 twaters@ecologycontrol.com http://www.ecologycontrol.com</p>	<p>For use in series with full capture device</p>
<p>Storage capacity: n/a</p>	<p>Replacement Parts: Available</p>
<p>Vendor's maintenance estimate: Weekly street sweeping schedule is required to prevent excessive buildup of debris. Inspect pan mechanism and remove debris as needed between May 1 and September 30</p>	<p>Warranty: 1 yr workmanship/3 yrs parts+materials</p>
<p>Material: Series 304 stainless steel</p>	<p>Delivery Time: Based on geographic location, quantity of order, and number of basin measurements per day. Within 90 days</p>
<p>Pricing: See over.</p>	

Comments from reference checks

Device effectiveness in capturing trash
Some problems in low-lying areas (Los Angeles)

Other:
Make sure screens are installed flush to curb

Bay Area-wide Trash Capture Demonstration Project

Funded by the Clean Water State Revolving Fund and the American Recovery and Reinvestment Act

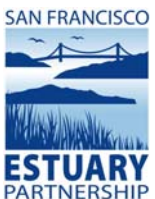

Bid Date Jan 25 2010 San Francisco Esaury Partnership Price Sheet

Item No.		Unit of Measure	Approx. Quantity	Automatic Retractable Curb Screens (ARS) Pricing	100% Full Capture Insert	
1	Furnish & Install ARS One Screen W<5'	EA	N/A	\$395.00		
2	Furnish & Install ARS Two Screen 5'<W<=8'	EA	N/A	\$770.00		
3	Furnish & Install ARS Three/4 Screen 8'<W<=15'	EA	N/A	\$1,190.00		
4	ARS Four/5 Screen 15'<W<=22'	EA	N/A	\$1,590.00		
5	Furnish & Install ARS Five Screen 22'<W<29'	EA	N/A	\$2,500.00		
6	Furnish & Install Full Capture Insert	EA	N/A		\$375.00	
	Item # P Quantity Discounts			0.00		
	Item # Q Alternate Prices Dependent Scope of Work			\$0.00		

Ecology Control Industries (American Stormwater)

ECI-1 Debris Dam

Device ID	Price per Unit
ECI-1	\$375.00

ECI-2 Surfgate (Automatic Retractable Screen)

Device ID	Size	# of Screens	Price per Unit
ECI-2a	0-5'	1	\$395.00
ECI-2b	5'-8'	2	\$770.00
ECI-2c	8'-15'	3-4	\$1190.00
ECI-2d	15'-22'	4-5	\$1590.00
ECI-2e	22'-29'	5	\$2500.00

High Flow Capacity Device

RMC-1HF Storm Flo Screen

Linear radial gross solids removal device (GSRD)



<p>Company Contact: Roscoe Moss Company, Los Angeles, CA Sales contact: Kevin McGillicuddy, 323-263-4111 kmc@roscoemoss.com http://roscoemoss.com</p>	<p>Meets San Francisco Bay Water Board full capture specifications</p>
<p>Storage capacity: 4.4-70.7 cubic feet depending on screen diameter</p>	<p>Replacement Parts: Available</p>
<p>Vendor's maintenance estimate: "It is recommended that the device be cleaned when half full. Cleaning the interior is best accomplished using a vehicle-based vacuum unit. The captured debris is accessed through large hatchways that are located on top of the screen. There is no maintenance required on the device itself other than cleaning of the interior."</p>	<p>Warranty: 2 yrs</p>
<p>Material: Type 304L or 316L grade steel, or galvanized steel</p>	<p>Delivery Time: Depending on size and number of devices, delivery is estimated to be 4 to 8 weeks from receipt of order</p>
<p>Pricing: See over.</p>	

Comments from reference checks

Device effectiveness in capturing trash

The overall effectiveness of capturing trash with the screen was excellent. The field performance and the vendor's claims regarding the amount of anticipated trash captured and the frequency of cleaning the device were the same.

Vendor does not install the device. The reference spoken to installed the device themselves and did not experience a large amount of rainfall. The reference recommends doubling the size of the device you think will handle the biggest storm event in your area. Installation requires know how and heavy-duty equipment.

Bay Area-wide Trash Capture Demonstration Project

Funded by the Clean Water State Revolving Fund and the American Recovery and Reinvestment Act



Attachment C

SF Bay Area-wide Trash Capture Device Demonstration Project

Storm Flo[®] Screen Price List

Diameter in.	1 - 5 ft screen + bypass	Each additional 5 ft screen	Each additional 10 ft screen
24.5	\$8,495.00	\$4,559.00	\$9,118.00
30.5	\$13,629.00	\$6,787.00	\$13,575.00
36.5	\$14,845.00	\$7,939.00	\$15,877.00
42.5	\$16,595.00	\$9,310.00	\$18,620.00
48.5	\$19,280.00	\$10,250.00	\$20,500.00

Notes:

Devices manufactured with 0.25" wall Type 304 stainless steel

Prices for galvanized steel discounted 15%, for SST 316L additional 30%

Devices include cost for structural bypass section - 3 ft long for diameters up to 42", 4 ft long for 48" dia.

Prices quoted FOB jobsite

Terms: through March 31, 2012

Roscoe Moss Company

RMC-1HF

StormFlo Screen

Device ID	Diameter	1-5ft Screen + Bypass	Each Additional 5ft Screen	Each Additional 10ft Screen
RMC-1HFa	24.5"	\$8,495.00	\$4,559.00	\$9,118.00
RMC-1HFb	30.5"	\$13,629.00	\$6,787.00	\$13,575.00
RMC-1HFc	36.5"	\$14,845.00	\$7,939.00	\$15,877.00
RMC-1HFd	42.5"	\$16,595.00	\$9,310.00	\$18,620.00
RMC-1HFe	48.5"	\$19,280.00	\$10,250.00	\$20,500.00

Notes:

Devices manufactured with 0.25" wall Type 304 stainless steel

Prices for galvanized steel discounted 15%, for SST 316L additional 30%

Devices include cost for structural bypass section - 3 ft long for diameters up to 42", 4 ft long for 48" dia.

Prices quoted FOB jobsite

Terms: through March 31, 2012

High Flow Capacity, Requires Water Board Approval

KS-11HF Nettech Gross Pollutant Trap- End of Line

End of pipe net



<p>Company Contact: KriStar Enterprises, Inc., Santa Rosa, CA Sales contact: Sue Lillo, 800-579-8819 slillo@kristar.com http://www.kristar.com</p>	<p>Certified full capture by LA Regional Water Board Meets San Francisco Bay Water Board full capture specifications</p>
<p>Storage capacity: range of capacities 4 to 319 cubic feet</p>	<p>Replacement Parts: Available</p>
<p>Vendor's maintenance estimate: "Depends on the amount of runoff, pollutant loading and interference from debris"</p>	<p>Warranty: Stainless steel 25yrs, netting materials 10yrs</p>
<p>Material: 304 stainless steel, flexible knit nylon mesh, and UV-resistant nylon netting</p>	<p>Delivery Time: 3-5 weeks from receipt of order</p>
<p>Pricing: See over.</p>	

Comments from reference checks

Maintenance Issues/Experience

"The net is supposed to collect debris and easily slip off. It never did. The cable system that wraps around the pipe had problems as well. We had problems getting the right tension for the net so that when the bag is full, it releases. It never released."

Bay Area-wide Trash Capture Demonstration Project

Funded by the Clean Water State Revolving Fund and the American Recovery and Reinvestment Act

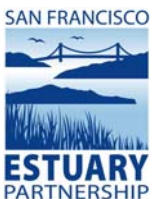

Bay Area-wide Trash Capture Demonstration Project
Appendix B- Item Q Pricing Schedule

Name of Proposing Company: KriStar Enterprises, Inc.
Name of Device: Nettech Gross Pollutant Trap

	NOMINAL PIPE DIAMETER	UNIT PRICE
Small	12" - 24"	\$ 5,950.00
Medium	30" - 48"	\$ 8,950.00
Large	54" - 72"	\$ 15,950.00

- (1) Actual dimensions will be field verified by KriStar prior to fabrication and installation
- (2) Products manufactured in accordance with Buy American contract provisions
- (3) Prices include manufacturer installation for interior or flange mount
- (4) Prices do not include any applicable sales taxes
- (5) There are no quantity purchase discounts available for this item

KS-9HF

FloGard Swirl-Flo Screen Separator

Device ID	Nominal Manhole Diameter	Unit Price
KS-9HF48	48"	\$ 3,650.00
KS-9HF60	60"	\$ 5,495.00
KS-9HF96	96"	\$14,950.00

NOTES:

- (1) Actual dimensions will be field verified by KriStar prior to fabrication and installation
- (2) Products manufactured in accordance with Buy American contract provisions
- (3) Prices include precast concrete components, bolted, gasketed lids, factory-installed internal components and delivery to jobsite
- (4) Purchaser is responsible for offloading and setting of structures
- (5) Prices do not include any applicable sales taxes
- (6) There is no purchase quantity discount available for this product

KS-10HF

Nettech Gross Pollutant Trap- In Line

Device ID	Nominal Pipe Diameter	Unit Price
KS-10HFs	12"-24"	\$ 5,950.00
KS-10HFm	30"-48"	\$ 8,950.00
KS-10HFI	54"-72"	\$15,950.00

- (1) Actual dimensions will be field verified by KriStar prior to fabrication and installation
- (2) Products manufactured in accordance with Buy American contract provisions
- (3) Prices include manufacturer installation for interior or flange mount
- (4) Prices do not include any applicable sales taxes
- (5) There are no quantity purchase discounts available for this item

KS-11HF

Nettech Gross Pollutant Trap- End of Line

Device ID	Nominal Pipe Diameter	Unit Price
KS-11HFs	12"-24"	\$ 5,950.00
KS-11HFm	30"-48"	\$ 8,950.00
KS-11HFI	54"-72"	\$15,950.00

- (1) Actual dimensions will be field verified by KriStar prior to fabrication and installation
- (2) Products manufactured in accordance with Buy American contract provisions
- (3) Prices include manufacturer installation for interior or flange mount
- (4) Prices do not include any applicable sales taxes
- (5) There are no quantity purchase discounts available for this item

High Flow Capacity Device

KS-10HF Nettech Gross Pollutant Trap — In Line

Inline gross pollutant trap

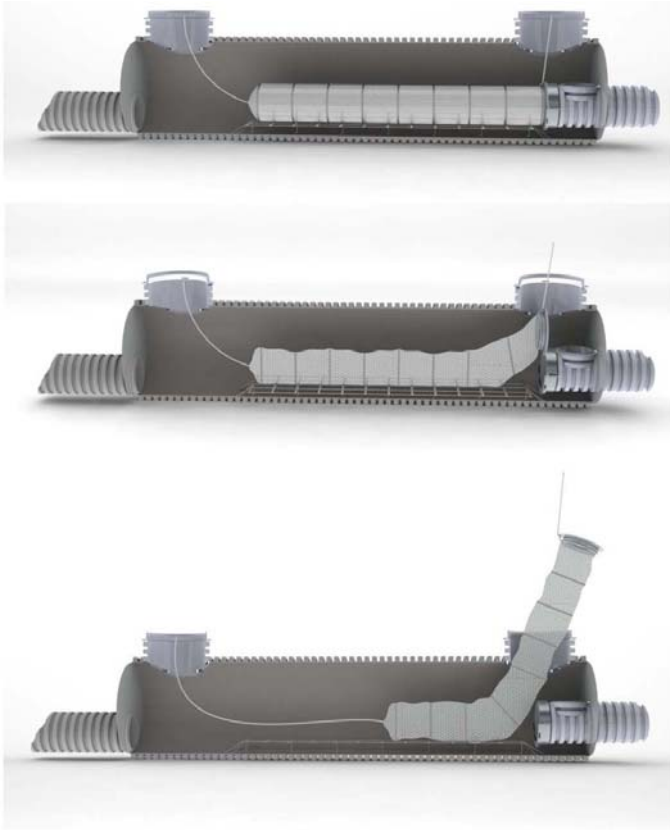

<p>Company Contact: KriStar Enterprises, Inc., Santa Rosa, CA Sales contact: Sue Lillo, 800-579-8819 slillo@kristar.com http://www.kristar.com</p>	<p>Meets San Francisco Bay Water Board full capture specifications</p>
<p>Storage capacity: rectangular (range of capacities from 0.4 to 10.5 cubic feet) round (range of capacities from 0.7 to 4.3 cubic feet)</p>	<p>Replacement Parts: Available</p>
<p>Vendor's maintenance estimate: "Depends on the amount of runoff, pollutant loading and interference from debris"</p>	<p>Warranty: 5 yrs</p>
<p>Material: 304 stainless steel, woven polypropylene geotextile, reinforced polypropylene geogrid, recycled polypropylene plastic</p>	<p>Delivery Time: 3-5 weeks from receipt of order</p>
<p>Pricing: See over.</p>	

Comments from reference checks

Device effectiveness in capturing trash

"The devices collect the majority of floatables. We are getting the desired results."

Bay Area-wide Trash Capture Demonstration Project

Funded by the Clean Water State Revolving Fund and the American Recovery and Reinvestment Act



Bay Area-wide Trash Capture Demonstration Project
Appendix B- Item Q Pricing Schedule

Name of Proposing Company: KriStar Enterprises, Inc.
Name of Device: Nettech Gross Pollutant Trap

	NOMINAL PIPE DIAMETER	UNIT PRICE
Small	12" - 24"	\$ 5,950.00
Medium	30" - 48"	\$ 8,950.00
Large	54" - 72"	\$ 15,950.00

- (1) Actual dimensions will be field verified by KriStar prior to fabrication and installation
- (2) Products manufactured in accordance with Buy American contract provisions
- (3) Prices include manufacturer installation for interior or flange mount
- (4) Prices do not include any applicable sales taxes
- (5) There are no quantity purchase discounts available for this item

KS-9HF

FloGard Swirl-Flo Screen Separator

Device ID	Nominal Manhole Diameter	Unit Price
KS-9HF48	48"	\$ 3,650.00
KS-9HF60	60"	\$ 5,495.00
KS-9HF96	96"	\$14,950.00

NOTES:

- (1) Actual dimensions will be field verified by KriStar prior to fabrication and installation
- (2) Products manufactured in accordance with Buy American contract provisions
- (3) Prices include precast concrete components, bolted, gasketed lids, factory-installed internal components and delivery to jobsite
- (4) Purchaser is responsible for offloading and setting of structures
- (5) Prices do not include any applicable sales taxes
- (6) There is no purchase quantity discount available for this product

KS-10HF

Nettech Gross Pollutant Trap- In Line

Device ID	Nominal Pipe Diameter	Unit Price
KS-10HFs	12"-24"	\$ 5,950.00
KS-10HFm	30"-48"	\$ 8,950.00
KS-10HFI	54"-72"	\$15,950.00

- (1) Actual dimensions will be field verified by KriStar prior to fabrication and installation
- (2) Products manufactured in accordance with Buy American contract provisions
- (3) Prices include manufacturer installation for interior or flange mount
- (4) Prices do not include any applicable sales taxes
- (5) There are no quantity purchase discounts available for this item

KS-11HF

Nettech Gross Pollutant Trap- End of Line

Device ID	Nominal Pipe Diameter	Unit Price
KS-11HFs	12"-24"	\$ 5,950.00
KS-11HFm	30"-48"	\$ 8,950.00
KS-11HFI	54"-72"	\$15,950.00

- (1) Actual dimensions will be field verified by KriStar prior to fabrication and installation
- (2) Products manufactured in accordance with Buy American contract provisions
- (3) Prices include manufacturer installation for interior or flange mount
- (4) Prices do not include any applicable sales taxes
- (5) There are no quantity purchase discounts available for this item

High Flow Capacity Device

KS-9HF FloGard Swirl-Flo Screen Separator trash capture screen for manhole

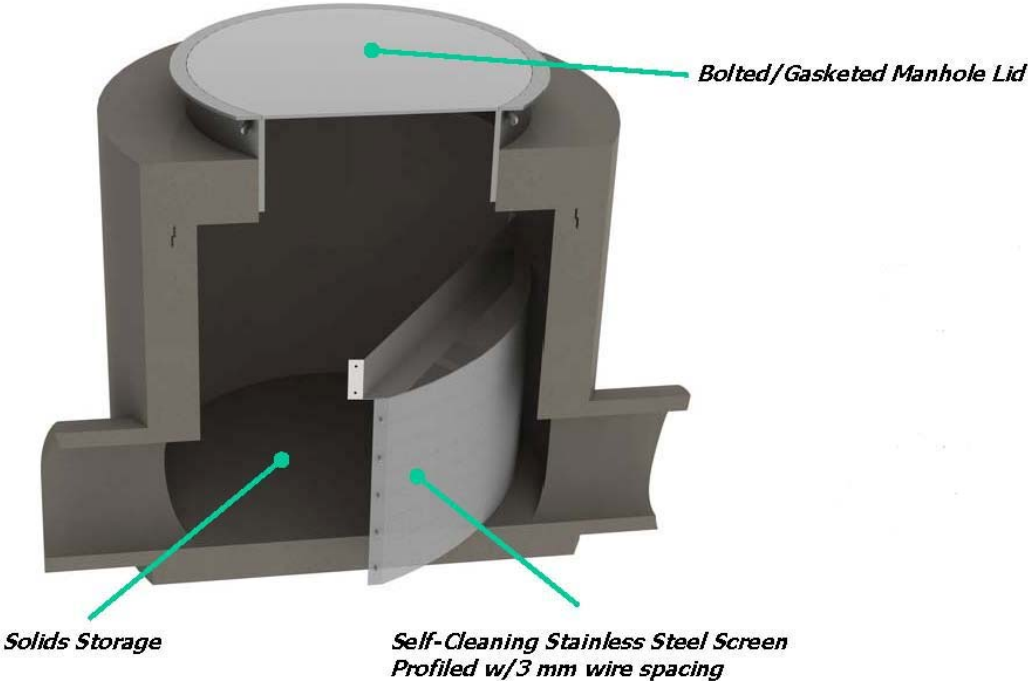

<p>Company Contact: KriStar Enterprises, Inc., Santa Rosa, CA Sales contact: Sue Lillo, 800-579-8819 slillo@kristar.com http://www.kristar.com</p>	<p>Meets San Francisco Bay Water Board full capture specifications</p>
<p>Storage capacity: 23-100 cubic feet depending on size of device</p>	<p>Replacement Parts: Available</p>
<p>Vendor's maintenance estimate: "It is generally recommended that filters be maintained when they have reached half their maximum storage volume."</p>	<p>Warranty: 5 yrs</p>
<p>Material: 304 stainless steel, precast concrete</p>	<p>Delivery Time: Typical time from receipt of order to installation will range from 3 to 5 weeks</p>
<p>Pricing: See over.</p>	



Bay Area-wide Trash Capture Demonstration Project
Appendix B- Item Q Pricing Schedule

Name of Proposing Company: KriStar Enterprises, Inc.
Name of Device: FloGard® Swirl-Flo Screen Separator

Nominal Manhole Diameter	List Price
48"	\$ 3,650.00
60"	\$ 5,495.00
96"	\$ 14,950.00

NOTES:

- (1) Actual dimensions will be field verified by KriStar prior to fabrication and installation
- (2) Products manufactured in accordance with Buy American contract provisions
- (3) Prices include precast concrete components, bolted, gasketed lids, factory-installed internal components and delivery to jobsite
- (4) Purchaser is responsible for offloading and setting of structures
- (5) Prices do not include any applicable sales taxes
- (6) There is no purchase quantity discount available for this product

KS-9HF

FloGard Swirl-Flo Screen Separator

Device ID	Nominal Manhole Diameter	Unit Price
KS-9HF48	48"	\$ 3,650.00
KS-9HF60	60"	\$ 5,495.00
KS-9HF96	96"	\$14,950.00

NOTES:

- (1) Actual dimensions will be field verified by KriStar prior to fabrication and installation
- (2) Products manufactured in accordance with Buy American contract provisions
- (3) Prices include precast concrete components, bolted, gasketed lids, factory-installed internal components and delivery to jobsite
- (4) Purchaser is responsible for offloading and setting of structures
- (5) Prices do not include any applicable sales taxes
- (6) There is no purchase quantity discount available for this product

KS-10HF

Nettech Gross Pollutant Trap- In Line

Device ID	Nominal Pipe Diameter	Unit Price
KS-10HF _s	12"-24"	\$ 5,950.00
KS-10HF _m	30"-48"	\$ 8,950.00
KS-10HF _I	54"-72"	\$15,950.00

- (1) Actual dimensions will be field verified by KriStar prior to fabrication and installation
- (2) Products manufactured in accordance with Buy American contract provisions
- (3) Prices include manufacturer installation for interior or flange mount
- (4) Prices do not include any applicable sales taxes
- (5) There are no quantity purchase discounts available for this item

KS-11HF

Nettech Gross Pollutant Trap- End of Line

Device ID	Nominal Pipe Diameter	Unit Price
KS-11HF _s	12"-24"	\$ 5,950.00
KS-11HF _m	30"-48"	\$ 8,950.00
KS-11HF _I	54"-72"	\$15,950.00

- (1) Actual dimensions will be field verified by KriStar prior to fabrication and installation
- (2) Products manufactured in accordance with Buy American contract provisions
- (3) Prices include manufacturer installation for interior or flange mount
- (4) Prices do not include any applicable sales taxes
- (5) There are no quantity purchase discounts available for this item

High Flow Capacity Device

KS-8HF FloGard® Perk Filter

Radial cartridge filter with trash capture screening

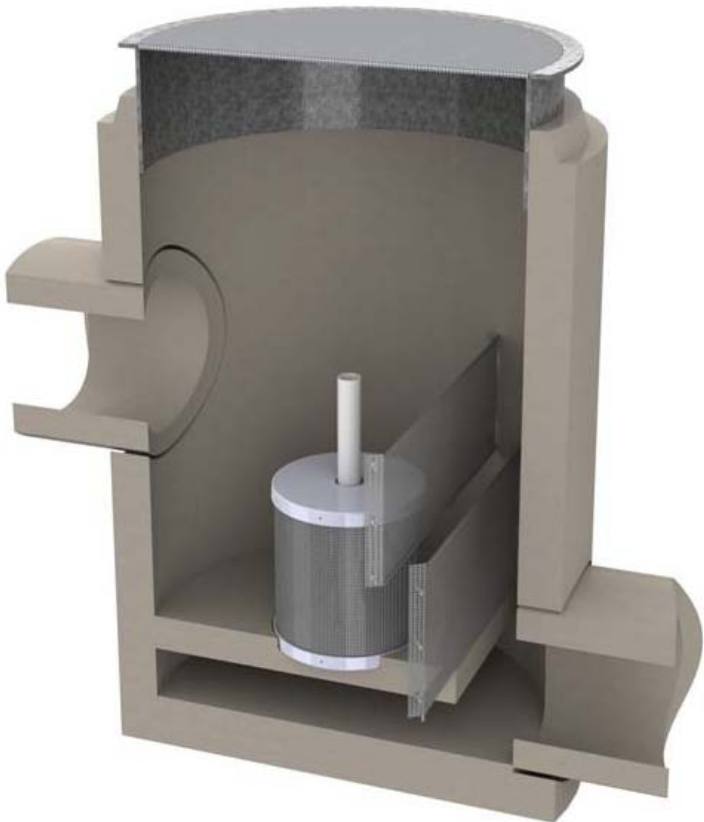

<p>Company Contact: KriStar Enterprises, Inc., Santa Rosa, CA Sales contact: Sue Lillo, 800-579-8819 slillo@kristar.com http://www.kristar.com</p>	<p>Meets San Francisco Bay Water Board full capture specifications</p>
<p>Storage capacity: 18-128 cubic feet depending on size of device</p>	<p>Replacement Parts: Available</p>
<p>Vendor's maintenance estimate: "It is generally recommended that filters be maintained when they have reached half their maximum storage volume."</p>	<p>Warranty: 5 yrs</p>
<p>Material: 304 stainless steel, precast concrete</p>	<p>Delivery Time: Typical time from receipt of order to installation will range from 3 to 5 weeks</p>
<p>Pricing: See over.</p>	

Bay Area-wide Trash Capture Demonstration Project

Funded by the Clean Water State Revolving Fund and the American Recovery and Reinvestment Act

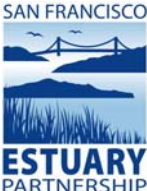

Bay Area-wide Trash Capture Demonstration Project
Appendix B- Item Q Pricing Schedule

Name of Proposing Company: KriStar Enterprises, Inc.
Name of Device: Perk Filter

Model	LIST PRICE
CF-50PFC136S	\$ 6,500.00
CF-49PF536S	\$ 23,700.00
CF-611PF1136S	\$ 41,600.00
CF-818PF3136S	\$ 85,750.00

NOTES:

- (1) Actual dimensions will be field verified by KriStar prior to fabrication and installation
- (2) Products manufactured in accordance with Buy American contract provisions
- (3) Prices include precast concrete components, bolted, gasketed lids, factory-installed internal components and delivery to jobsite
- (4) Purchaser is responsible for offloading and setting of structures
- (4) Prices do not include any applicable sales taxes
- (5) There is no purchase quantity discount available for this product

KS-7HF

FloGard Dual-Vortex Hydrodynamic Separator

Device ID	Unit Price
KS-7HF36	\$ 5,500.00
KS-7HF48	\$ 8,500.00
KS-7HF60	\$10,500.00
KS-7HF72	\$16,000.00
KS-7HF84	\$22,500.00
KS-7HF96	\$ 29,500.00
KS-7HF120	\$42,500.00
KS-7HF144	\$57,500.00

NOTES:

- (1) Actual dimensions will be field verified by KriStar prior to fabrication and installation
- (2) Products manufactured in accordance with Buy American contract provisions
- (3) Prices include circular or square pre-cast concrete structures, joint sealant, factory installed internal components and access cover assemblies.
- (4) Purchaser is responsible for offloading and setting of structures
- (4) Prices do not include any applicable sales taxes
- (5) There is no purchase quantity discount available for this product

KS-8HF

FloGard Perk Filter

Device ID	Unit Price
KS-8HF50	\$ 6,500.00
KS-8HF49	\$ 23,700.00
KS-8HF611	\$41,600.00
KS-8HF818	\$85,750.00

NOTES:

- (1) Actual dimensions will be field verified by KriStar prior to fabrication and installation
- (2) Products manufactured in accordance with Buy American contract provisions
- (3) Prices include precast concrete components, bolted, gasketed lids, factory-installed internal components and delivery to jobsite
- (4) Purchaser is responsible for offloading and setting of structures
- (4) Prices do not include any applicable sales taxes
- (5) There is no purchase quantity discount available for this product

High Flow Capacity Device

KS-7HF FloGard® Dual-Vortex Hydrodynamic Separator Hydrodynamic separator with trash capture screen

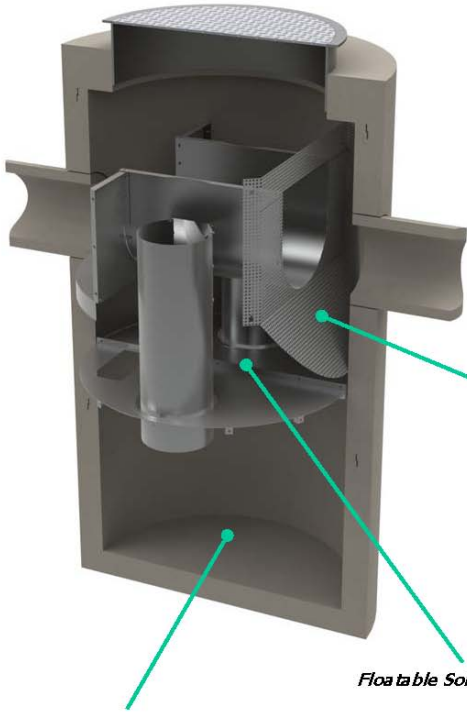

TRASH REMOVAL CAPACITY CHART				
Model	Inside Diameter (in)	Settleable Solids Storage (cu ft)	Floatable Solids Storage (cu ft)	Treated Flow Capacity (cfs)
DVS-36-S	36	8	6	0.50
DVS-48-S	48	18	15	1.25
DVS-60-S	60	35	29	2.50
DVS-72-S	72	60	50	4.25
DVS-84-S	84	95	82	6.50
DVS-96-S	96	142	123	9.50
DVS-120-S	120	278	242	16.8
DVS-144-S	144	481	416	26.4

*Inclined Outlet Screen
Type 304 Stainless Steel
0.1875 in / 4.76 mm
Staggered Round Perforations*



Settleable Solids Storage

Floatable Solids Storage

<p>Company Contact: KriStar Enterprises, Inc., Santa Rosa, CA Sales contact: Sue Lillo, 800-579-8819 slillo@kristar.com http://www.kristar.com</p>	<p>Meets San Francisco Bay Water Board full capture specifications</p>
<p>Storage capacity: 8-481 cubic feet depending on size of device</p>	<p>Replacement Parts: Available</p>
<p>Vendor's maintenance estimate: "It is generally recommended that filters be maintained when they have reached half their maximum storage volume."</p>	<p>Warranty: 5 yrs</p>
<p>Material: 304 stainless steel, precast concrete</p>	<p>Delivery Time: Typical time from receipt of order to installation will range from 3 to 5 weeks</p>
<p>Pricing: See over.</p>	
<p>Installed: City of Fremont</p>	

Bay Area-wide Trash Capture Demonstration Project

Funded by the Clean Water State Revolving Fund and the American Recovery and Reinvestment Act



Bay Area-wide Trash Capture Demonstration Project
Appendix B- Item Q Pricing Schedule

Name of Proposing Company: KriStar Enterprises, Inc.
Name of Device: FloGard® Dual Vortex Hydrodynamic Separator

Model	LIST PRICE
DVS-36	\$5,500.00
DVS-48	\$ 8,500.00
DVS-60	\$ 10,500.00
DVS-72	\$ 16,000.00
DVS-84	\$ 22,500.00
DVS-96	\$ 29,500.00
DVS-120	\$ 42,500.00
DVS-144	\$ 57,500.00

NOTES:

- (1) Actual dimensions will be field verified by KriStar prior to fabrication and installation
- (2) Products manufactured in accordance with Buy American contract provisions
- (3) Prices include circular or square pre-cast concrete structures, joint sealant, factory installed internal components and access cover assemblies.
- (4) Purchaser is responsible for offloading and setting of structures
- (4) Prices do not include any applicable sales taxes
- (5) There is no purchase quantity discount available for this product

KS-7HF

FloGard Dual-Vortex Hydrodynamic Separator

Device ID	Unit Price
KS-7HF36	\$ 5,500.00
KS-7HF48	\$ 8,500.00
KS-7HF60	\$10,500.00
KS-7HF72	\$16,000.00
KS-7HF84	\$22,500.00
KS-7HF96	\$ 29,500.00
KS-7HF120	\$42,500.00
KS-7HF144	\$57,500.00

NOTES:

- (1) Actual dimensions will be field verified by KriStar prior to fabrication and installation
- (2) Products manufactured in accordance with Buy American contract provisions
- (3) Prices include circular or square pre-cast concrete structures, joint sealant, factory installed internal components and access cover assemblies.
- (4) Purchaser is responsible for offloading and setting of structures
- (4) Prices do not include any applicable sales taxes
- (5) There is no purchase quantity discount available for this product

KS-8HF

FloGard Perk Filter

Device ID	Unit Price
KS-8HF50	\$ 6,500.00
KS-8HF49	\$ 23,700.00
KS-8HF611	\$41,600.00
KS-8HF818	\$85,750.00

NOTES:

- (1) Actual dimensions will be field verified by KriStar prior to fabrication and installation
- (2) Products manufactured in accordance with Buy American contract provisions
- (3) Prices include precast concrete components, bolted, gasketed lids, factory-installed internal components and delivery to jobsite
- (4) Purchaser is responsible for offloading and setting of structures
- (4) Prices do not include any applicable sales taxes
- (5) There is no purchase quantity discount available for this product

High Flow Capacity Device

KS-6HF Downstream Defender Hydrodynamic separator with trash capture screen

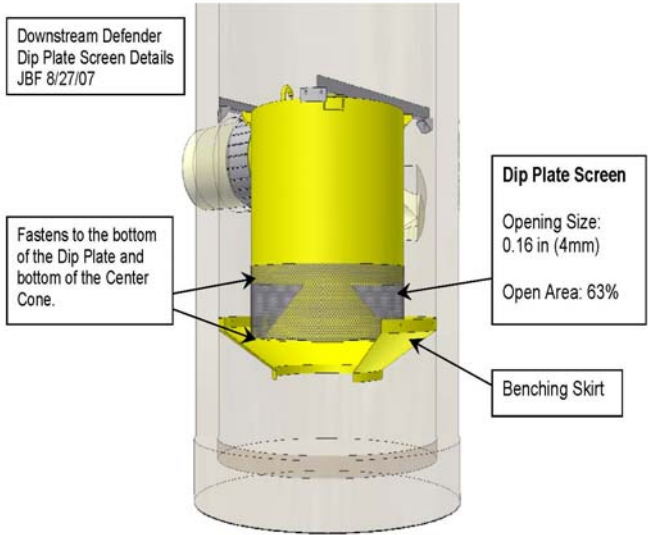

<p>Company Contact: KriStar Enterprises, Inc., Santa Rosa, CA Sales contact: Sue Lillo, 800-579-8819 slillo@kristar.com http://www.kristar.com</p>	<p>Meets San Francisco Bay Water Board full capture specifications</p>
<p>Storage capacity: 21.2 cubic feet for 6 foot model</p>	<p>Replacement Parts: Available</p>
<p>Vendor's maintenance estimate: "The frequency of the sump vac procedure is determined in the field after installation. During the first year of operation, the units should be inspected every six months to determine the rate of sediment and floatables accumulation."</p>	<p>Warranty: 5 yrs</p>
<p>Material: 304 stainless steel, aluminum alloy, cross-linked high density polyethylene, co-polymer polypropylene</p>	<p>Delivery Time: Typical time from receipt of order to installation will range from 3 to 5 weeks</p>
<p>Pricing: See over.</p>	
<p>Installed: At Los Angeles International Airport (LAX)</p>	

Comments from reference checks

Device effectiveness in capturing trash

One reference reported poor performance. Installation at LAX was in process at time of call.

Good customer service; durable device

Bay Area-wide Trash Capture Demonstration Project

Funded by the Clean Water State Revolving Fund and the American Recovery and Reinvestment Act

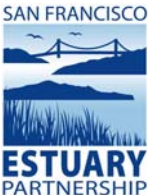

Bay Area-wide Trash Capture Demonstration Project
Appendix B- Item Q Pricing Schedule

Name of Proposing Company: KriStar Enterprises, Inc.
Name of Device: Downstream Defender

Model	LIST PRICE
DD-4	\$ 12,900.00
DD-6	\$ 22,500.00
DD-8	\$ 37,500.00
DD-10	\$ 65,000.00

NOTES:

- (1) Actual dimensions will be field verified by KriStar prior to fabrication and installation
- (2) Products manufactured in accordance with Buy American contract provisions
- (3) Prices include precast concrete components, bolted, gasketed lids, factory-installed internal components and delivery to jobsite
- (4) Purchaser is responsible for offloading and setting of structures
- (5) Prices do not include diversion structures
- (6) Prices do not include any applicable sales taxes
- (7) There is no purchase quantity discount available for this product

- (4) Prices do not include any applicable sales taxes
- (5) There are no quantity purchase discounts available for this item

KS-4

Trash and Debris Guards (stainless steel)

Device ID	Unit Price
KS-4	\$ 375.00

Large Devices

KS-5HF

Cleans All Gross Pollutant Trap

Device ID	Unit Price
KS-5HF	Pricing for this product is estimated to range from \$60,000 to \$220,000 per installation. Each location will need to be individually evaluated to determine final pricing based upon the site specific conditions.

KS-6HF

Downstream Defender

Device ID	Unit Price
KS-6HF4	\$ 12,900.00
KS-6HF6	\$ 22,500.00
KS-6HF8	\$37,500.00
KS-6HF10	\$65,000.00

NOTES:

- (1) Actual dimensions will be field verified by KriStar prior to fabrication and installation
- (2) Products manufactured in accordance with Buy American contract provisions
- (3) Prices include precast concrete components, bolted, gasketed lids, factory-installed internal components and delivery to jobsite
- (4) Purchaser is responsible for offloading and setting of structures
- (5) Prices do not include diversion structures
- (6) Prices do not include any applicable sales taxes
- (7) There is no purchase quantity discount available for this product

High Flow Capacity Device

KS-5HF CleansAll Gross pollutant trap

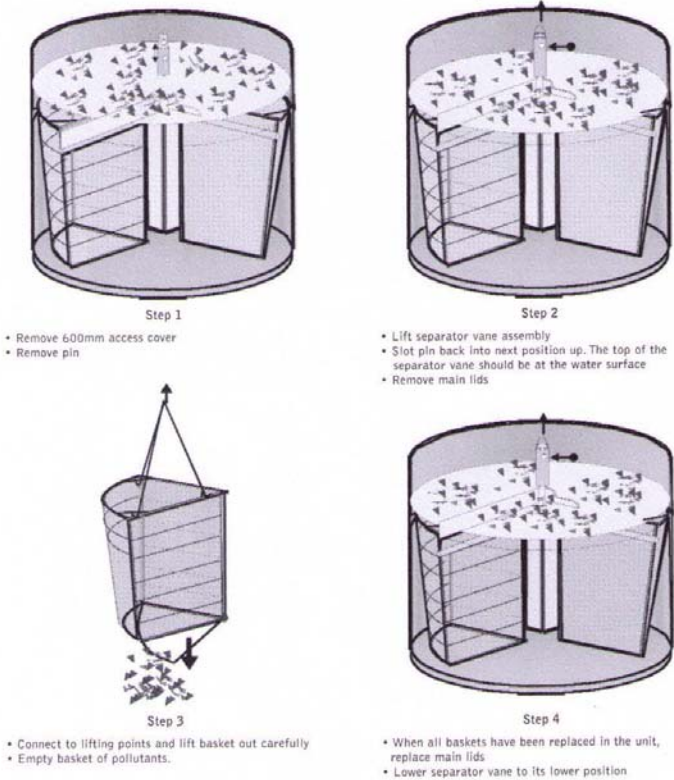
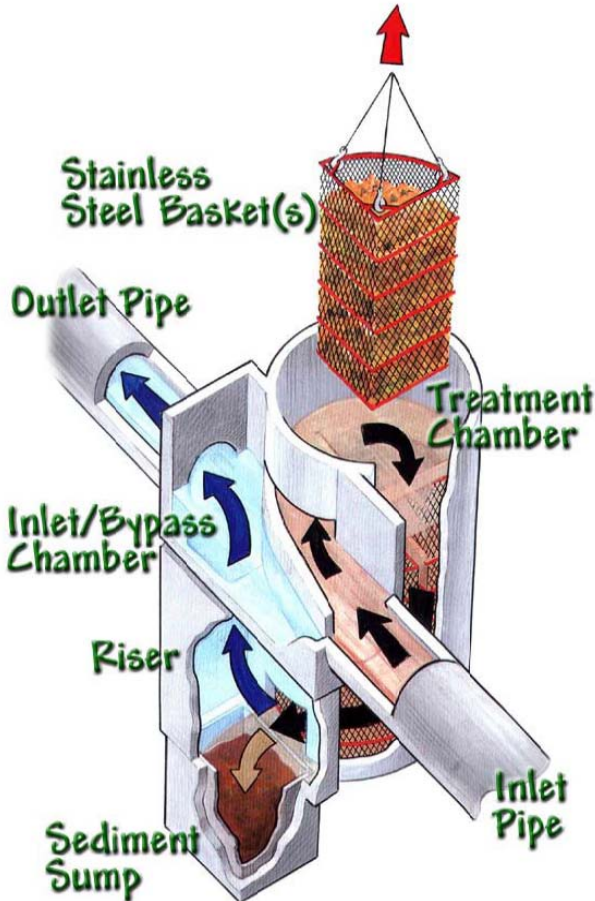

Maintenance Procedure

<p>Company Contact: KriStar Enterprises, Inc., Santa Rosa, CA Sales contact: Sue Lillo, 800-579-8819 slillo@kristar.com http://www.kristar.com</p>	<p>Meets San Francisco Bay Water Board full capture specifications</p>
<p>Storage capacity: 0.46-13.9 cubic yard depending on size of device</p>	<p>Replacement Parts: Available</p>
<p>Vendor's maintenance estimate: Vendor refers to diagram above</p>	<p>Warranty: 5 yrs</p>
<p>Material: 304 stainless steel, precast concrete</p>	<p>Delivery Time: Typical time from receipt of order to installation will range from 3 to 5 weeks</p>
<p>Pricing: "Pricing for this product is estimated to range from \$60,000 to \$220,000 per installation. Each location will need to be individually evaluated to determine final pricing based upon the site-specific conditions".</p>	

No reference available

Bay Area-wide Trash Capture Demonstration Project

Funded by the Clean Water State Revolving Fund and the American Recovery and Reinvestment Act

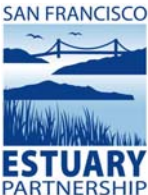

Pricing for this product is estimated to range from \$60,000.00 to \$220,000.00 per installation. Each location will need to be individually evaluated to determine final pricing based upon the site specific conditions.

- (4) Prices do not include any applicable sales taxes
- (5) There are no quantity purchase discounts available for this item

KS-4

Trash and Debris Guards (stainless steel)

Device ID	Unit Price
KS-4	\$ 375.00

Large Devices

KS-5HF

Cleans All Gross Pollutant Trap

Device ID	Unit Price
KS-5HF	Pricing for this product is estimated to range from \$60,000 to \$220,000 per installation. Each location will need to be individually evaluated to determine final pricing based upon the site specific conditions.

KS-6HF

Downstream Defender

Device ID	Unit Price
KS-6HF4	\$ 12,900.00
KS-6HF6	\$ 22,500.00
KS-6HF8	\$37,500.00
KS-6HF10	\$65,000.00

NOTES:

- (1) Actual dimensions will be field verified by KriStar prior to fabrication and installation
- (2) Products manufactured in accordance with Buy American contract provisions
- (3) Prices include precast concrete components, bolted, gasketed lids, factory-installed internal components and delivery to jobsite
- (4) Purchaser is responsible for offloading and setting of structures
- (5) Prices do not include diversion structures
- (6) Prices do not include any applicable sales taxes
- (7) There is no purchase quantity discount available for this product

High Flow Capacity, Requires Water Board Approval

FCT-2HF End of Pipe Netting Trash Trap

End of pipe net

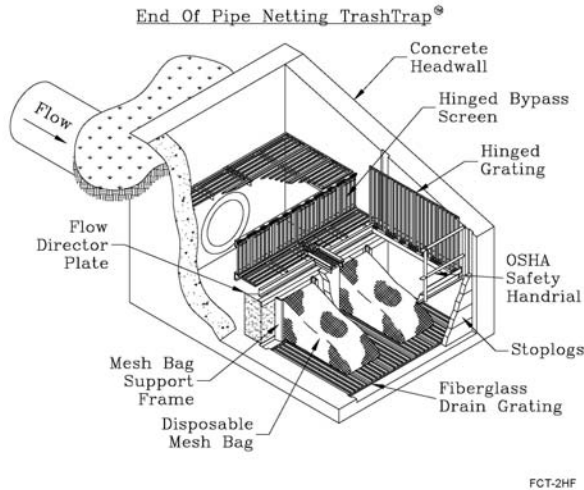

<p>Company Contact: Fresh Creek Technologies, Inc., Cedar Grove, NJ Sales contact: Walter C. Trnka, 215-272-8213 wtrnka@freshcreek.com http://www.freshcreek.com</p>	<p>If net is 5mm, meets trash capture minimum specifications</p>
<p>Storage capacity: "The storage capacity for one net can be estimated between 200 to 2000 pounds of wet trash and debris with at volume density of 50lbs per cubic foot."</p>	<p>Replacement Parts: Available</p>
<p>Vendor's maintenance estimate: "Net change is routinely accomplished in under 30 minutes. Frequency of net change determined by wet weather events and the amount of trash in the flow"</p>	<p>Warranty: 2 yrs</p>
<p>Material: Nylon nets, plastic or wooden frames, 316 stainless steel bypass screen and removal device, fiberglass drain grating</p>	<p>Delivery Time: Delivery to site is 6-8 weeks after the receipt of approved drawings.</p>
<p>Pricing: See over.</p>	

Comments from reference checks

Device effectiveness in capturing trash

"We are not getting the materials that we expected. The net works as a great leaf catcher. We are getting more leaves than trash."

"It performed well. We tried different netting devices from different vendors. We shifted back to Fresh Creek."

Maintenance issues/experience

"..storms caused some damage to the device. The doors bent upwards due to the severe nature of the flows." Netting had to be modified to accommodate fish passage

Bay Area-wide Trash Capture Demonstration Project

Funded by the Clean Water State Revolving Fund and the American Recovery and Reinvestment Act





Attachment "P"

Confidential

1425 Pompton Ave. Ste 1-2, Cedar Grove, NJ 07009
 800-741-9487
 973-237-9099
 973-237-0744(Fax)
www.freshcreek.com

**Price-Product Matrix High Flow Capacity Trash Capture Devices
 in the San Francisco Bay Region**

Date: February 2, 2010

Flow rate	<u>In-Line - FLNTT</u>			
	# Nets	Equipment Price	Installation Price	Total
1241-2480 cfs	40	\$3,798,116	\$9,495,290	\$13,293,405
621-1240 cfs	20	\$1,913,624	\$4,784,060	\$6,697,684
249-620 cfs	10	\$971,378	\$2,428,445	\$3,399,823
125-248 cfs	4	\$406,031	\$1,015,076	\$1,421,107
63-124 cfs	2	\$217,581	\$543,954	\$761,535
5-62 cfs	1	\$123,357	\$308,392	\$431,749
0-5 cfs	1	\$40,000	\$100,000	\$140,000

Flow rate	<u>End-of-Pipe - EOPNTT</u>			
	# Nets	Equipment Price	Installation Price	Total
1241-2480 cfs	40	\$2,379,871	\$4,759,742	\$7,139,613
621-1240 cfs	20	\$1,204,502	\$2,409,003	\$3,613,505
249-620 cfs	10	\$616,817	\$1,233,634	\$1,850,451
125-248 cfs	4	\$264,206	\$528,412	\$792,618
63-124 cfs	2	\$146,669	\$293,338	\$440,007
5-62 cfs	1	\$87,901	\$175,801	\$263,702

Flow rate	<u>Floating - FLNTT</u>			
	# Nets	Equipment Price	Installation Price	Total
1241-2480 cfs	10	\$839,551	\$1,259,327	\$2,098,878
621-1240 cfs	4	\$353,300	\$529,950	\$883,249
249-620 cfs	2	\$191,216	\$286,824	\$478,040
125-248 cfs	2	\$191,216	\$286,824	\$478,040
63-124 cfs	2	\$191,216	\$286,824	\$478,040
5-62 cfs	2	\$191,216	\$286,824	\$478,040

Notes:

1. Nets for the In-Line and End-of-Pipe are 30"W x 60"H at the opening.
2. Nets for the Floating are 30"W x 30"H at the opening.
3. All Netting TrashTrap® nets are made of heavy duty Nylon or resin coated heavy duty Nylon, where applicable.
4. Nets are nominally 8 feet long. Other lengths are available based on size, design, flow and velocity.
5. Net mesh opening size used is 5 mm. Other sizes are available.
6. Nets are designed for nominal 5 feet/second at the net frame opening.
7. All Netting TrashTrap systems are constructed of 316 stainless steel.
8. Concrete chambers are included with the in-line style @ a Invert of 6'-0", but End-of-Pipe and Floating do not include any concrete.
9. Total installed cost will be a function of the site conditions, elevation, and inverts, but in the installation price above was calculated using the following factors:
 - a. In-Line Systems Factor 2.5 x Equipment Price
 - b. End-of-Pipe Systems Factor 2.0 x Equipment Price
 - c. Floating System Factor 1.5 x Equipment Price
10. Prices subject to change pending contract execution.

This correspondence and all attachments contain information proprietary to Fresh Creek Technologies, Incorporated. It is submitted in confidence and is to be used solely for the purpose for which it is furnished and returned upon request. This information is not to be reproduced, transmitted, disclosed, or used otherwise in whole or in part without the written authorization of Fresh Creek Technologies, Incorporated.

FCT-1HF
Fresh Creek Technologies
In-Line Netting Trash Trap

Device ID	Flow Rate	In-Line #Nets	Equipment Price	Installation Price	Total
FCT-1HFa	1241-2480 cfs	40	\$3,798,116	\$9,495,290	\$13,293,405
FCT-1HFB	621-1240 cfs	20	\$1,913,624	\$4,784,060	\$6,697,684
FCT-1HFc	249-620 cfs	10	\$971,378	\$2,428,445	\$3,399,823
FCT-1HFd	125-248 cfs	4	\$406,031	\$1,015,076	\$1,421,107
FCT-1HFe	63-124 cfs	2	\$217,581	\$543,954	\$761,535
FCT-1HFf	5-62 cfs	1	\$123,357	\$308,392	\$431,749
FCT-1HFg	0-5 cfs	1	\$40,000	\$100,000	\$140,000

FCT-2HF
Fresh Creek Technologies
End of Pipe Netting Trash Trap

Device ID	Flow Rate	End of Pipe #Nets	Equipment Price	Installation Price	Total
FCT-2HFa	1241-2480 cfs	40	\$2,379,871	\$4,759,742	\$7,139,613
FCT-2HFB	621-1240 cfs	20	\$1,204,502	\$2,409,003	\$3,613,505
FCT-2HFc	249-620 cfs	10	\$616,817	\$1,233,634	\$1,850,451
FCT-2HFd	125-248cfs	4	\$264,206	\$528,412	\$792,618
FCT-2HFe	63-124 cfs	2	\$146,669	\$293,338	\$440,007
FCT-2HFf	5-62 cfs	1	\$87,901	\$175,801	\$263,702

Notes:

1. Nets for the In-Line and End-of-Pipe are 30"W x 60"H at the opening.
2. Nets for the Floating are 30"W x 30"H at the opening.
3. All Netting TrashTrap® nets are made of heavy duty Nylon or resin coated heavy duty Nylon, where applicable.
4. Nets are nominally 8 feet long. Other lengths are available based on size, design, flow and velocity.
5. Net mesh opening size used is 5 mm. Other sizes are available.
6. Nets are designed for nominal 5 feet/second at the net frame opening.
7. All Netting TrashTrap systems are constructed of 316 stainless steel.
8. Concrete chambers are included with the in-line style @ a Invert of 6'-0", but End-of-Pipe and Floating do not include any concrete.
9. Total installed cost will be a function of the site conditions, elevation, and inverts, but in the installation price above was calculated using the following factors:
 - a. In-Line Systems Factor 2.5 x Equipment Price
 - b. End-of-Pipe Systems Factor 2.0 x Equipment Price
 - c. Floating System Factor 1.5 x Equipment Price
10. Prices subject to change pending contract execution.

FCT-1HF Inline Netting Trash Trap

Inline pipe net

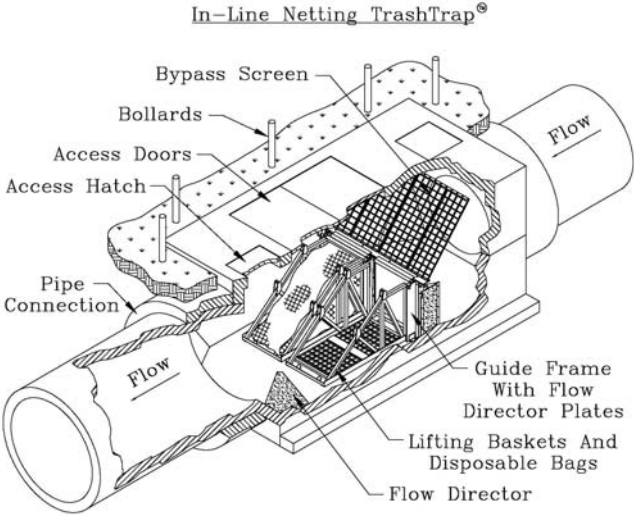

FCT-1HF

<p>Company Contact: Fresh Creek Technologies, Inc., Cedar Grove, NJ Sales contact: Walter C. Trnka, 215-272-8213 wtrnka@freshcreek.com http://www.freshcreek.com</p>	<p>If net is 5mm, meets trash capture minimum specifications</p>
<p>Storage capacity: "The storage capacity for one net can be estimated between 200 to 2000 pounds of wet trash and debris with at volume density of 50lbs per cubic foot."</p>	<p>Replacement Parts: Available</p>
<p>Vendor's maintenance estimate: "Net change is routinely accomplished in under 30 minutes, frequency of net change determined by wet weather events and the amount of trash in the flow"</p>	<p>Warranty: 2 yrs</p>
<p>Material: Nylon nets, plastic or wooden frames, 316 stainless steel bypass screen and removal device, fiberglass drain grating</p>	<p>Delivery Time: The delivery to site is 6-8 weeks after the receipt of the approved drawings.</p>
<p>Pricing: See over.</p>	

Comments from reference checks

Device effectiveness in capturing trash

"The device is incredible. Depending on future funding, our plan is to purchase additional nets." "It performed well. We tried different netting devices from different vendors. We shifted back to Fresh Creek." "The netting trash trap is operating as designed and functions as designed."

Maintenance issues/experience

Fresh Creek has come out to reposition the nets to alleviate problems." "Trash traps installed in high trash areas will require more maintenance. You do not need to enter vault to perform maintenance. A small crane is required to remove nets."

Bay Area-wide Trash Capture Demonstration Project

Funded by the Clean Water State Revolving Fund and the American Recovery and Reinvestment Act

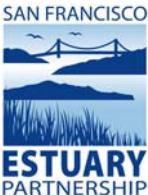



Attachment "P"

Confidential

1425 Pompton Ave. Ste 1-2, Cedar Grove, NJ 07009
 800-741-9487
 973-237-9099
 973-237-0744(Fax)
www.freshcreek.com

**Price-Product Matrix High Flow Capacity Trash Capture Devices
 in the San Francisco Bay Region**

Date: February 2, 2010

Flow rate	<u>In-Line - FLNTT</u>			
	# Nets	Equipment Price	Installation Price	Total
1241-2480 cfs	40	\$3,798,116	\$9,495,290	\$13,293,405
621-1240 cfs	20	\$1,913,624	\$4,784,060	\$6,697,684
249-620 cfs	10	\$971,378	\$2,428,445	\$3,399,823
125-248 cfs	4	\$406,031	\$1,015,076	\$1,421,107
63-124 cfs	2	\$217,581	\$543,954	\$761,535
5-62 cfs	1	\$123,357	\$308,392	\$431,749
0-5 cfs	1	\$40,000	\$100,000	\$140,000

Flow rate	<u>End-of-Pipe - EOPNTT</u>			
	# Nets	Equipment Price	Installation Price	Total
1241-2480 cfs	40	\$2,379,871	\$4,759,742	\$7,139,613
621-1240 cfs	20	\$1,204,502	\$2,409,003	\$3,613,505
249-620 cfs	10	\$616,817	\$1,233,634	\$1,850,451
125-248 cfs	4	\$264,206	\$528,412	\$792,618
63-124 cfs	2	\$146,669	\$293,338	\$440,007
5-62 cfs	1	\$87,901	\$175,801	\$263,702

Flow rate	<u>Floating - FLNTT</u>			
	# Nets	Equipment Price	Installation Price	Total
1241-2480 cfs	10	\$839,551	\$1,259,327	\$2,098,878
621-1240 cfs	4	\$353,300	\$529,950	\$883,249
249-620 cfs	2	\$191,216	\$286,824	\$478,040
125-248 cfs	2	\$191,216	\$286,824	\$478,040
63-124 cfs	2	\$191,216	\$286,824	\$478,040
5-62 cfs	2	\$191,216	\$286,824	\$478,040

Notes:

1. Nets for the In-Line and End-of-Pipe are 30"W x 60"H at the opening.
2. Nets for the Floating are 30"W x 30"H at the opening.
3. All Netting TrashTrap® nets are made of heavy duty Nylon or resin coated heavy duty Nylon, where applicable.
4. Nets are nominally 8 feet long. Other lengths are available based on size, design, flow and velocity.
5. Net mesh opening size used is 5 mm. Other sizes are available.
6. Nets are designed for nominal 5 feet/second at the net frame opening.
7. All Netting TrashTrap systems are constructed of 316 stainless steel.
8. Concrete chambers are included with the in-line style @ a Invert of 6'-0", but End-of-Pipe and Floating do not include any concrete.
9. Total installed cost will be a function of the site conditions, elevation, and inverts, but in the installation price above was calculated using the following factors:
 - a. In-Line Systems Factor 2.5 x Equipment Price
 - b. End-of-Pipe Systems Factor 2.0 x Equipment Price
 - c. Floating System Factor 1.5 x Equipment Price
10. Prices subject to change pending contract execution.

This correspondence and all attachments contain information proprietary to Fresh Creek Technologies, Incorporated. It is submitted in confidence and is to be used solely for the purpose for which it is furnished and returned upon request. This information is not to be reproduced, transmitted, disclosed, or used otherwise in whole or in part without the written authorization of Fresh Creek Technologies, Incorporated.

FCT-1HF
Fresh Creek Technologies
In-Line Netting Trash Trap

Device ID	Flow Rate	In-Line #Nets	Equipment Price	Installation Price	Total
FCT-1HFa	1241-2480 cfs	40	\$3,798,116	\$9,495,290	\$13,293,405
FCT-1HFB	621-1240 cfs	20	\$1,913,624	\$4,784,060	\$6,697,684
FCT-1HFc	249-620 cfs	10	\$971,378	\$2,428,445	\$3,399,823
FCT-1HFD	125-248 cfs	4	\$406,031	\$1,015,076	\$1,421,107
FCT-1HFE	63-124 cfs	2	\$217,581	\$543,954	\$761,535
FCT-1HFF	5-62 cfs	1	\$123,357	\$308,392	\$431,749
FCT-1HFG	0-5 cfs	1	\$40,000	\$100,000	\$140,000

FCT-2HF
Fresh Creek Technologies
End of Pipe Netting Trash Trap

Device ID	Flow Rate	End of Pipe #Nets	Equipment Price	Installation Price	Total
FCT-2HFa	1241-2480 cfs	40	\$2,379,871	\$4,759,742	\$7,139,613
FCT-2HFB	621-1240 cfs	20	\$1,204,502	\$2,409,003	\$3,613,505
FCT-2HFc	249-620 cfs	10	\$616,817	\$1,233,634	\$1,850,451
FCT-2HFD	125-248cfs	4	\$264,206	\$528,412	\$792,618
FCT-2HFE	63-124 cfs	2	\$146,669	\$293,338	\$440,007
FCT-2HFF	5-62 cfs	1	\$87,901	\$175,801	\$263,702

Notes:

1. Nets for the In-Line and End-of-Pipe are 30"W x 60"H at the opening.
2. Nets for the Floating are 30"W x 30"H at the opening.
3. All Netting TrashTrap® nets are made of heavy duty Nylon or resin coated heavy duty Nylon, where applicable.
4. Nets are nominally 8 feet long. Other lengths are available based on size, design, flow and velocity.
5. Net mesh opening size used is 5 mm. Other sizes are available.
6. Nets are designed for nominal 5 feet/second at the net frame opening.
7. All Netting TrashTrap systems are constructed of 316 stainless steel.
8. Concrete chambers are included with the in-line style @ a Invert of 6'-0", but End-of-Pipe and Floating do not include any concrete.
9. Total installed cost will be a function of the site conditions, elevation, and inverts, but in the installation price above was calculated using the following factors:
 - a. In-Line Systems Factor 2.5 x Equipment Price
 - b. End-of-Pipe Systems Factor 2.0 x Equipment Price
 - c. Floating System Factor 1.5 x Equipment Price
10. Prices subject to change pending contract execution.

CCP-1HF **Continuous Deflective Separator (CDS)**
Hydrodynamic separator

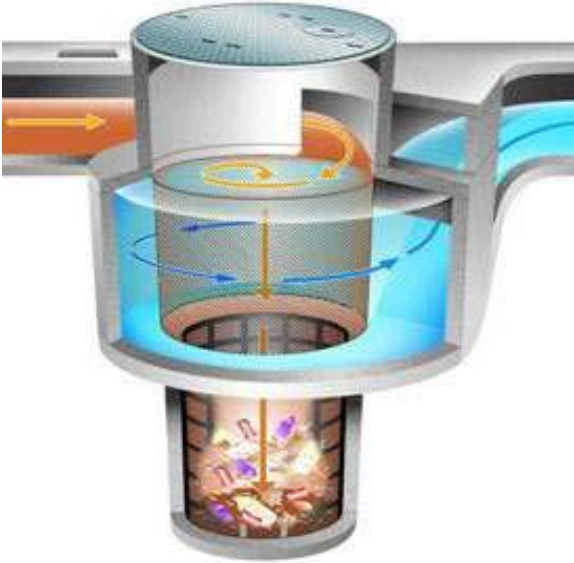

<p>Company Contact: Contech Construction Products, Novato, CA Sales contact: Curt Kruger, 415-897-8587 or Paul Jacob, 925-283-1205 krugerc@contech-cpi.com jacobp@contech-cpi.com http://contech-cpi.com</p>	<p>Meets San Francisco Bay Water Board full capture specifications</p>
<p>Storage capacity: 25-134 cubic feet depending on size</p>	<p>Replacement Parts: Available</p>
<p>Vendor’s maintenance estimate: "We recommend at least two inspections during the first year of operation, with the inspection schedule adjusted thereafter based on experience. The rate at which the system collects pollutants will depend more heavily on site activities than the size of the unit."</p>	<p>Delivery Time: Lead time is 3-6 weeks after release to manufacture. If final construction drawings do not accompany the order, then delivery is 3-6 weeks after such drawings are approved.</p>
<p>Material: concrete, fiberglass, stainless steel, cast iron</p>	<p>Warranty: 2 yrs</p>
<p>Pricing: See over.</p>	

Comments from reference checks

Device effectiveness in capturing trash

"Trash is mostly removed. The first flush captures all the trash."

Maintenance issues/experience

Also captures sediments, oil and grease. "Each unit requires less and less maintenance after the first flush. Vector control is an issue. CDS units capture a lot of trash." "Vector control is an issue. I suggest plugging some of the holes to prevent vectors from entering the unit." "I would suggest the addition of a screen to keep vectors out of the top of the CDS unit. We had a problem with a lot of mosquitoes one year." "Due to its large footprint and required depth placement, I would also evaluate smaller and similar products (e.g., Vortechincs) that CONTECH markets. They may work just as well as a CDS unit."

Bay Area-wide Trash Capture Demonstration Project

Funded by the Clean Water State Revolving Fund and the American Recovery and Reinvestment Act



Prices below DO NOT include installation:

Size A	\$9,180	Size K	\$45,306
Size B	\$10,260	Size L	\$43,481 *
Size C	\$12,830	Size M	\$44,312 *
Size D	\$17,993	Size N	\$51,440 *
Size E	\$23,760	Size O	\$63,202 *
Size F	\$27,130	Size P	\$77,101 *
Size G	\$29,938	Size Q	\$79,477 *
Size H	\$32,141	Size R	\$147,692 *
Size I	\$34,333	Size S	\$156,229 *
Size J	\$39,917	Size T	\$164,339 *

Quantity Discount: 3 or more of Sizes A-K ordered at the same time, 10% discount

*Diversion Box likely required

Typical Diversion Box Prices:

6' x 12'	\$13,000
8' x 14'	\$15,000
12' x 18'	\$19,000

CCP-1HF
Continuous Deflective Separator

Prices DO NOT include installation.

Device ID	Size (manufacturer reference)	Price	Diversion Box Likely Required
CCP-1HFa	A	\$9,180.00	
CCP-1HFb	B	\$10,260.00	
CCP-1HFc	C	\$12,830.00	
CCP-1HFd	D	\$17,993.00	
CCP-1HFe	E	\$23,760.00	
CCP-1HFf	F	\$27,130.00	
CCP-1HFg	G	\$29,938.00	
CCP-1HFh	H	\$32,141.00	
CCP-1HFi	I	\$34,333.00	
CCP-1HFj	J	\$39,917.00	
CCP-1HFk	K	\$45,306.00	
CCP-1HFl	L	\$43,481.00	*
CCP-1HFm	M	\$44,312.00	*
CCP-1HFn	N	\$51,440.00	*
CCP-1HFo	O	\$63,202.00	*
CCP-1HFp	P	\$77,101.00	*
CCP-1HFq	Q	\$79,477.00	*
CCP-1HFr	R	\$147,692.00	*
CCP-1HFs	S	\$156,229.00	*
CCP-1HFt	T	\$164,339.00	*

Quantity Discount: 3 or more of sizes A-K ordered at the same time, 10% discount.

* = Diversion box likely required

Diversion Box Prices:

Device ID	Size	Price
CCP-1HFd1	6' X 12'	\$13,000
CCP-1HFd2	8' X 14'	\$15,000
CCP-1HFd3	12' X 18'	\$19,000

BC-5HF Nutrient Separating Baffle Box

Inline treatment system for Total Suspended Solids, Hydrocarbons (oils and grease), and Gross Solids

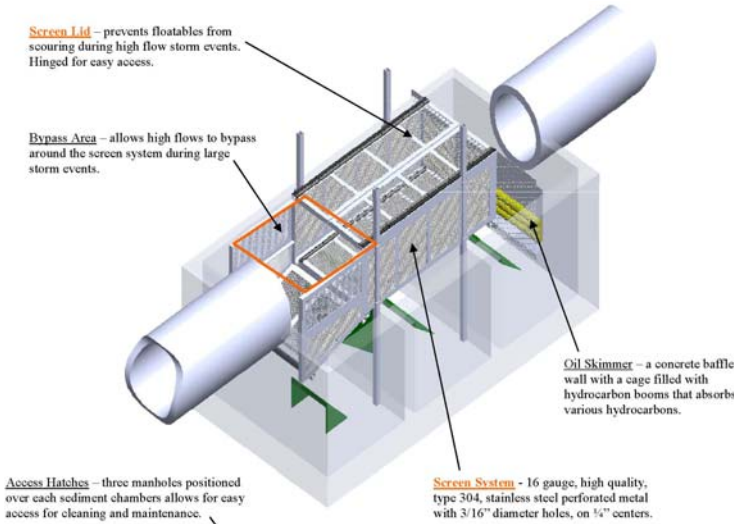

<p>Company Contact: Bio Clean Environmental Services, Inc., Oceanside, CA Sales contacts: Greg Kent, (760) 433-7640 or Kirk Vallejo, (760) 681-9583 gkent@biocleanenvironmental.net kvallejo@biocleanenvironmental.net http://www.biocleanenvironmental.com</p>	<p>Meets San Francisco Bay Water Board full capture specifications</p>
<p>Storage capacity: "The treatment capacity of this NSBB can easily exceed the one-year, one-hour intensity when properly sized."</p>	<p>Replacement Parts: Available</p>
<p>Vendor's maintenance estimate: "inspect a minimum of once every six months; cleaning and debris removal maintenance, minimum of once a year; replacement of hydrocarbon booms, once a year."</p>	<p>Warranty: 5 yrs</p>
<p>Material: precast concrete, 6061-T6 aluminum, stainless steel, steel reinforcement, laminated fiberglass</p>	<p>Delivery Time: 1 to 5 units, 8 weeks; 6 to 15 units, 10 weeks; 16 to 25 units, 12-16 weeks</p>
<p>Pricing: See over.</p>	

No reference information available

Nutrient Separating Baffle Box

Price for Standard Built Box - Grade to 5 Feet of Cover or Less

Normal Soil Conditions and No Groundwater

Price Does Not Include Delivery to Jobsite Unless Otherwise Noted**

NSBB Model	Price per System	Discounted Price - 6 to 20	Discounted Price - 21 and Over	Delivery Cost
4-6.5-72	\$17,768.00	\$16,879.00	\$15,991.00	Per Job*
4-8-84	\$19,448.00	\$18,475.00	\$17,503.00	Per Job*
5-10-84	\$22,844.00	\$21,701.00	\$20,559.00	Per Job*
6-12-84	\$27,123.00	\$25,766.00	\$24,410.00	Per Job*
8-12-96	\$35,197.00	\$33,437.00	\$31,677.00	Per Job*
8-14-96	\$37,941.00	\$36,043.00	\$34,146.00	Per Job*
10-14-96	\$44,000.00	\$41,800.00	\$39,600.00	Per Job*
11-16-114	\$68,500.00*	\$65,075.00	\$61,650.00	\$5,000.00

Additional Cost to Above Pricing for Corrosive Soil Conditions or Groundwater Installation

Custom Engineered Box - Installation at Over 5 Feet of Cover

Depth of Box, Soil Conditions and Groundwater are Unknown Factors and Costs Vary Per Job

Prices are Based Upon Standard Pricing and Actual Costs for Special Concrete Mixtures and Wall Thickness

NSBB Model	Price per System	Discounted Price - 6 to 20	Discounted Price - 21 and Over	Delivery Cost
4-6.5-72	Per Quote	Per Quote	Per Quote	Per Job*
4-8-84	Per Quote	Per Quote	Per Quote	Per Job*
5-10-84	Per Quote	Per Quote	Per Quote	Per Job*
6-12-84	Per Quote	Per Quote	Per Quote	Per Job*
6-12-96	Per Quote	Per Quote	Per Quote	Per Job*
8-14-96	Per Quote	Per Quote	Per Quote	Per Job*
10-14-96	Per Quote	Per Quote	Per Quote	Per Job*
11-16-114	Per Quote	Per Quote	Per Quote	\$5,000.00

Pricing Includes:

304 Stainless Steel Basket with 4.75 mm Openings(Full Capture)

Assistance with Preliminary Design

NSBB Drawing Stamped by Engineer

Supervision at Installation

*Delivery Charge from Plant in Pleasanton, California is Based Upon Mileage to Jobsite

**Delivery Charge is \$5,000.00 from Manufacturing Plant in Fontana, California

5 Year Warranty



Southern California
2972 San Lus Rey Rd.
Oceanside, CA 92058
Phone 760-433-7640

Northern California
690 Sunol St.
San Jose, CA 95126
Phone 760-579-1584

BC-5HF Nutrient Separating Baffle Box

**Price for Standard Built Box - Grade to 5 Feet of Cover or Less
Normal Soil Conditions and No Groundwater**

Price Does Not Include Delivery to Jobsite Unless Otherwise Noted**

Device ID	Model #	Price per system	Discounted Price 6-20	Discounted Price 21 and over	Delivery Cost
BC-5HFa	4-6.5-72	\$17,768.00	\$16,879.00	\$15,991.00	Per Job
BC-5HFb	4-8-84	\$19,448.00	\$18,475.00	\$17,503.00	Per Job
BC-5HFc	5-10-84	\$22,844.00	\$21,701.00	\$20,559.00	Per Job
BC-5HFd	6-12-84	\$27,123.00	\$25,766.00	\$24,410.00	Per Job
BC-5HFe	8-12-96	\$35,197.00	\$33,437.00	\$31,677.00	Per Job
BC-5HFf	8-14-96	\$37,941.00	\$36,043.00	\$34,146.00	Per Job
BC-5HFg	10-14-96	\$44,000.00	\$41,800.00	\$39,600.00	Per Job
BC-5HFh	11-16-114	\$68,500.00	\$65,075.00	\$61,650.00	\$5,000.00

Additional Cost to Above Pricing for Corrosive Soil Conditions or Groundwater Installation

Pricing Includes:

304 Stainless Steel Basket with 4.75 mm Openings (Full Capture)
Assistance with Preliminary Design
NSBB Drawing Stamped by Engineer
Supervision at Installation